

# UniFlow Laboratory Fume Hoods®



UniFlow SE Hoods



UniFlow LE Hoods



UniFlow FM Hoods

- ✓ UniFlow AireStream Laboratory Fume Hoods
- ✓ Fume Hood Service Components
- ✓ Special Purpose Hoods
- ✓ UniMax Large Floor Mount Hoods
- ✓ Laboratory Ventilation
- ✓ Laboratory Safety Equipment
- ✓ EnviroMax Vented Enclosures



UniMax Large Floor Mount Hoods



**HEMCO**  
Laboratory Planning Solutions





# Welcome to HEMCO

Made in the  U.S.A.

HEMCO is the leading manufacturer of innovative laboratory equipment serving the Sciences and R&D Technology Industries since 1958. Located in Independence, Missouri, the heart of America, and the crossroads of North America a major center for transportation, communication, distribution, and manufacturing industries worldwide.

HEMCO's modern manufacturing and distribution facilities combined with our many years of experience uniquely qualifies us to provide laboratory planning solutions. Our extensive engineering, design and manufacturing expertise can transform your laboratory ideas into reality.

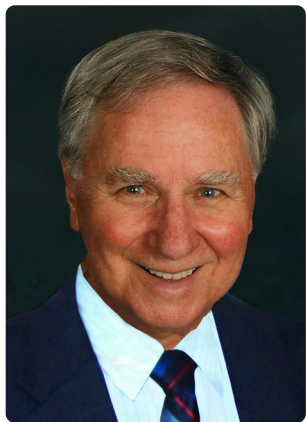

Ronald E. Hill P.E.  
CEO & Co-Founder

## HEMCO celebrated it's 66th anniversary in 2024.

*"This is quite an accomplishment for a small start up business. We were honored by the Mayor of Independence." 2008 was our 50th year, and as we progress into the next 50 years, we look forward to continued growth and service to the industries we serve.*

*One of our most important associations over the past 30 years is our membership in SEFA (Scientific Equipment & Furniture Association) which this year marks SEFA's 31st anniversary. HEMCO is proud to be one of the founding members since 1988. SEFA is a growing and preferred association that represents all Laboratory Fume Hood Furniture Manufacturers worldwide.*

## HEMCO's Membership in Technical Associations, Inspires Innovation

The year 2009 marked a new beginning for HEMCO, we became an ISO 9001:2008 certified company. In 2018 HEMCO became an ISO 9001:2015 certified company. The International Standard Organization is recognized in the USA and 178 countries worldwide. HEMCO's management team has adopted the ISO quality management and procedures into our daily operating system. By continuing to improve manufacturing procedures & operations, it creates efficiency with employee involvement. "We say what we do and we do what we say" We strive to make our customers experience number 1, with our prompt service. Completing projects on time and within budget.

The next year, 2010, HEMCO's UniFlow SE Aire Stream, UniFlow LE & UniFlow CE fume hoods became U.L. classified to U.L. 1805 standards for laboratory fume hoods & cabinets. Underwriter Laboratories have 69 labs and certified testing facilities in the US, and over 100 countries worldwide, with 6,600 employees to service the U.L. clients. U.L. has tested HEMCO HiPel composite fiberglass laminate for chemical & flame resistance and to NFPA 45 for plastics suitable to use in the laboratory. HEMCO's fume hoods are tested to meet U.L. standard 3101 for electrical circuitry & are listed and compliant to U.L. 1805 -3101, CSA, and CE classifications.

Consider UniFlow Fume Hoods on your next lab project.

**Thank You and as Always Welcome to HEMCO**



HEMCO's 50th Anniversary



National Society of Professional Engineers & MSPE Lifetime Member



Scientific Equipment & Furniture Association Lifetime Member



American Chemical Society Chemical Health & Safety Member Since 1989



International Society of Pharmaceutical Engineers Member Since 1994



American Society of Heating, Refrigeration & Air Conditioning Engineers Lifetime Member



International Institute for Sustainable Laboratories Member Since 2002



UL Underwriters Laboratories Certified 1805 and 3101 Since 2010



ISO 9001:2015 Certified Company Since 2009



American Institute of Architects Member Since 2013



Association of Energy Engineers Member Since 2012



National Fire Protection Association Member Since 2012

# We invite you to explore our laboratory product lines

## UNIFLOW LABORATORY FUME HOODS Page

UniFlow Fume Hoods.....	1
Traditional vs UniFlow Fume Hoods.....	2
UniFlow SE AireStream Fume Hoods.....	3-4
UniFlow LE AireStream Fume Hoods.....	5-6
UniFlow CE AireStream Fume Hoods.....	7-8
Plan-A-Hood Worksheet.....	9

## FUME HOOD SERVICE COMPONENTS Page

Work Surfaces, Base Cabinets, Acid Cabinets.....	10
Wall Mounted Plumbing Fixtures.....	11
Fume Hood Electrical Services.....	12
Sinks and Neutralization Tanks.....	13
Apparatus Grids & Fire Extinguishers.....	14

## SPECIAL PURPOSE FUME HOODS Page

UniFlow SE (Walk-In) Fume Hoods.....	15-16
UniFlow LE (Walk-In) Fume Hoods.....	17-18
UniFlow SE Dual Entry Fume Hoods.....	19-20
UniFlow LE Dual Entry Fume Hoods.....	21-22
UniFlow Auxiliary Air Fume Hoods.....	23-24
UniFlow Perchloric Acid Fume Hoods.....	25-26
UniFlow HDPE Acid Digestion Fume Hoods...27-28	
UniFlow Polypro Trace Metals Fume Hoods...29-30	
UniFlow Radioisotope Fume Hoods.....	31-32
UniFlow Fume Hood Chemical Applications.....	33
Chemical Resistance Chart.....	34
UniMax Large Floor Mount Fume Hoods.....	35-36

## FUME HOOD VENTILATION Page

Lab Ventilation Recommendations.....	37
Energy Saving Recommendations.....	38
Fume Hood Ventilation & Duct Design.....	39
Fume Hood Ducting.....	40
Fume Hood Blowers Ordering Info.....	41
Fume Hood Blowers.....	42
Clean Aire InLine HEPA Filtration.....	43
Clean Aire InLine Carbon Filtration.....	44
Polypropylene InLine Fume Hood Scrubbers.....	45
Clean Aire InLine Fume Hood Scrubbers.....	46

## LABORATORY FURNITURE Page

Laboratory Furniture Groupings.....	47-48
-------------------------------------	-------

## LABORATORY SAFETY EQUIPMENT Page

Canopy Hoods FRP and Stainless steel.....	49
Emergency Shower Eye/Face wash Decontamination Booth.....	50

## ENVIROMAX ENCLOSURES Page

EnviroMax Vented Enclosures.....	51-52
----------------------------------	-------





# UniFlow® AireStream Laboratory Fume Hoods



UniFlow SE Aire Stream 60 inch laboratory fume hood #45521 shown with optional service fixtures, plumbing & electrical, air flow monitor, worksurface, base cabinets and accessories. HEMCO recommends fume hoods be equipped with an air flow monitor, per OSHA 29 CFR part 1910.



✓ HEMCO offers a complete line of UniFlow laboratory fume hoods. Bench-mounted hoods in widths from 24" to 96". Floor-mounted (walk-in) hoods from 48" to 144" wide and up to 96" deep. UniFlow fume hoods are designed for performance, user protection, & save 50% on reduced energy cost.

U.L., Underwriters Laboratory U.L. 1805 for fume hoods & cabinets, this classification covers construction, materials, flammability, & containment. U.L. 3101 electrical performance is tested using HIPOT testing, (high potential high voltage). HEMCO's test facility is compliant to test fume hoods for U.L.1805 Classification.

✓ CSA, Canadian Standards Associations  
CAN/CSA - C22.2 compliant for electrical components

✓ CE European Conforming International  
Electrical Configuration

✓ OSHA, Occupational Health & Safety Federal Register  
29 CFR part 1910

✓ SEFA, Scientific Equipment Furniture Association,  
SEFA 1-2010 recommended practices for fume hoods

✓ ASHRAE, American Society of Heating, Refrigerating  
and Air-Conditioning Engineers, ASHRAE - 110, 1995

✓ ANSI, American National Standards Institute,  
Z9.5, 2012 Laboratory Ventilation

✓ ASTM, American Society for Testing and  
Materials ASTM E-84, 2001

✓ NFPA, National Fire Protection Association, NFPA - 45, 2000

✓ ISO 9001: 2015 Certified Company

✓ UniFlow Fume Hoods are listed on [ARCAT.com](http://ARCAT.com)

✓ 5 year warranty on all UniFlow SE, LE & CE AireStream models which are U.L. 1805 classified, guaranteed

## Advantages of UniFlow CAV Bypass Fume Hoods

**Cut Energy Costs up to 50%, by reducing the size of the blower & ductwork required, while lowering installation costs. (see page 38)**

1. Important: by incorporating Sash Management 1-2-3, you are saving 50% on overall energy costs, and providing the best possible user protection & safety.
2. Recommended that hoods be used with sash 1/2 open with face velocity of 80-100 FPM. Sash stop located at 1/2 open position. With upper sash raised to the 1/2 open position the supply air CFM & static pressure are as noted. (see page 4)
3. Sash in full open position should be for setup of apparatus & maintenance service only. If design opening is at 1/2 open at 100 FPM, face velocity at full open would be approximately 50 FPM. The recommended face velocity for efficiency & safety is 80-100 FPM. Lower face velocity may compromise user safety.
4. When hood is not in use, keep sash in closed position.
5. Sash stops are standard on U.L. Classified Fume Hoods. UniFlow SE, LE and CE AirStream fume hoods
6. The Sash Stop is designed for user protection and CFM reduction. Allows sash to open to a maximum of half open, providing up to 50% energy savings.
7. Sash at full open is primarily designed for set-up of equipment and maintenance. Fume hood users should wear personal safety protection equipment, consult Lab Safety Officer.
8. HEMCO recommends 10-12 room air changes per hour for the health & safety of personnel. Example 10' X 20' room 10' high receiving 10 room air changes per hour requires 350 CFM air flow through the lab.
9. At an average utility rate of \$7.00 per CFM, a typical annual savings on a 4' fume hood would be \$2705.00 and on a 6' fume hood \$4067.00, by using Sash Management 1-2-3., Sash Stop at 50% open.

Standard Color is Lab White, other colors are available.

Lab White - 01	Silver Beige - 02	Pewter Gray - 03	Zircon Blue - 04



# Traditional Fume Hoods vs UniFlow Fume Hoods

Innovation is the Difference Between the Same Perspective and an Entirely New one.



The 1925 Ford Tri-motor, featured all metal construction, no wood. Its fuselage and wings were constructed of corrugated sheet metal, for strength. These aircraft were well-designed, and reliable (for the era).



The Boeing 787 Dreamliner features aerodynamic composite construction. Composites have a higher strength to weight ratio, which helps to make the 787 a lighter more energy efficient aircraft.

## Traditional Fume Hoods



Wt 435 lbs

## 1. Fully Assembled Fume Hoods

**Traditional Fume Hood 60" wide** Constructed of formed painted sheet metal panels & held together with sheet metal fasteners & brackets. Chemical resistant interior liner panels with sharp corners sealed with caulking. 1 year warranty. Heavy, challenging installation.  
**Weight 435 lbs**

**UniFlow SE Fume Hood 60" wide** Unitized composite superstructure for total chemical resistance. non-metallic construction. Interior fume chamber one-piece glass smooth, all covered corners for ease of cleaning, 5 year warranty. Unitized construction reduces weight for ease of installation.  
**Weight 265 lbs**

**Weight savings difference = 170 lbs**

## UniFlow SE Fume Hoods



Wt 265 lbs

## 2. Disassembled Fume Hoods



Wt 435 lbs

**Traditional Fume Hood 60" wide** 170 bolts, nuts and screws removed. 14 painted sheet metal panels with fasteners & brackets removed. 8 flat composite liner panels, no caulk to seal cracks, includes sash assembly & 36" fluorescent 2 bulb T-8 light fixture with steel painted white reflector.  
**Weight 435 lbs**

**UniFlow SE Fume Hood 60" wide** Unitized construction for superior durability and long life. Meets NFPA 45 for fire resistance in laboratories. Includes sash assembly & Vapor proof LED light fixture with polished Stainless steel reflector.

**Weight 265 lbs**

**Weight savings difference = 170 lbs**



Wt 265 lbs

## 3. Fume Chamber Composite Panels



Flat Panels

Wt 139 lbs

**Traditional Fume Hood 60" wide** 8 composite liner panels to fabricate fume chamber. No caulking or sealant in corner cracks. The ceiling panel shown with sheet metal vent outlet. Sash assembly and light assembly removed.  
**Weight 139 lbs**

**UniFlow SE Fume Hood 60" wide** Unitized composite superstructure for total chemical resistance. non-metallic construction. Interior fume chamber one-piece glass smooth, all covered corners no joints, 5 year warranty. Unitized construction reduces weight for ease of installation. Sash assembly and light assembly removed.  
**Weight 210 lbs**



Wt 210 lbs Unitized Superstructure

### Customer Comments:

Based on the nature of the products we analyze (sulfur chlorides, sulfuric acids, oleums), fume hoods last about two to three years. At the end of three years the chemicals have corroded both the exterior steel panels and the internal steel frame work of the metal hoods. We replaced them eight years ago with HEMCO UniFlow fiberglass fume hoods. The installation was easier, and we have had no repairs since then. We are building a new facility, and we plan to install HEMCO hoods.

Steve Mixon, Chief Chemist

# UniFlow<sup>®</sup> SE AireStream Fume Hoods

High efficiency, full duty fume hood in 48", 60", 72" and 96" widths. UniFlow SE AireStream Fume Hoods are designed for energy savings & maximum user protection. The aerodynamic face opening with airfoil provides uniform air flow through the fume chamber. A constant volume low flow hood with Vector Baffle System directs the air through the fume chamber to the bell shaped exhaust collar with minimal turbulence. Requires Remote Exhaust Blower. Fume hood is U.L.1805 classified.



**UniFlow SE AireStream Hood Cat. No. 45621** shown with optional epoxy resin worksurface, acid storage cabinet, & fixtures. See pages 10-14 for accessories.

**UniFlow Superstructure** non-metallic construction, total chemical and corrosion resistance, superior durability and long life. Interior fume chamber one-piece glass smooth, all covered corners for ease of cleaning. Unitized construction reduces weight for ease of installation. 5 year warranty.

## UniFlow AireStream Vector Baffle

System Features Vector Air Flow Slots for low flow and high performance. Maintains uniform air flow thru the baffle system to bell shaped exhaust collar outlet.

## Access Panel

removable to access ducting connections, plumbing & electrical services from a single point electrical box, 115/60Hz AC operation.

## Vapor Proof LED light fixture

polished stainless steel reflectors, and light switch on left column, all factory installed. Energy efficient 15W, 50/60Hz, 100-277VAC. 5 Year warranty. U.L. Listed

## 28" Vertical Sash Height

provides ease of access for apparatus set-up in fume chamber. Sash is perfectly counter balanced, 3/16 tempered safety glass, coated stainless steel cable with stainless steel pulley assembly. Framed in nonmetallic PVC framing, track, and aerodynamic sash lift for ease of movement and air flow efficiency. Standard Sash.

## 35" Viewing Height

interior fume chamber with 24" or 30" interior reach in depth. With 54" interior working height, allowing for tall apparatus and distillation grid.

## Angled Picture Frame Opening

the aerodynamic face opening with air foil provides uniform air flow into the fume chamber and thru the Vector AireStream Baffle System.



**Air Flow Monitor** (Optional equipment) continuously monitors face velocity air flow, meets ANSI and OSHA requirements.

**Cat. No. 51403** (see page 39)

## SASH OPTIONS

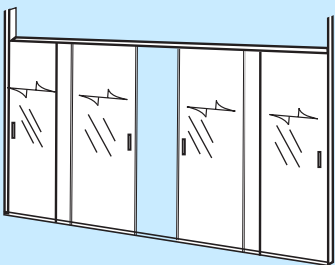

### Horizontal Sashes

Max opening is 50%, (4) panels on (2) tracks, conveniently lift out for equipment set-up or cleaning. For 50% reduction of air supply.

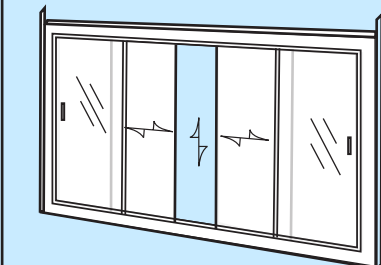

### Combination Horizontal / Vertical Sash

Offers the advantages of both sash types. Horizontal sash offer energy savings while vertical option allows full access to the fume chamber. Frame is of type 304 stainless steel. (see page 4 number 6)

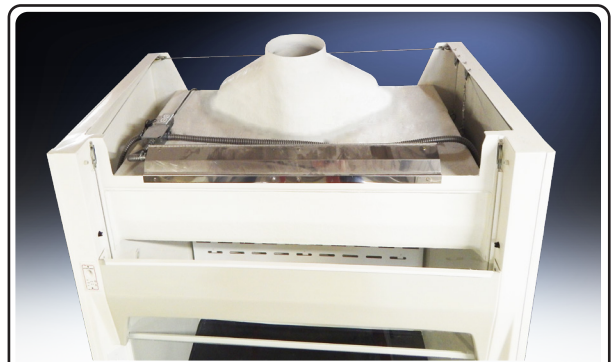

### Low Resistance Exhaust Collar

Engineered to reduce static pressure and improve air flow volume & efficiency.

10" Diameter Exhaust Collar.....**Cat.No. 80101**

12" Diameter Exhaust Collar.....**Cat.No. 80121**



# UniFlow SE AireStream Fume Hoods

UNIFLOW SE AIRESTREAM DESCRIPTIONS	Hood Depth "B"	Fume Hood Width "A"			
		48" Cat.No.	60" Cat.No.	72" Cat.No.	96" Cat.No.
<b>1. UniFlow SE AireStream CAV Fume Hood:</b> Air Bypass low flow, constant air volume hood. Dual wall unitized construction, all non-metallic corrosion and fire resistant composite fiberglass construction. Vector AireStream Baffle System and transition bell exhaust connection. Molded one-piece fume chamber with white glass-smooth surface with all covered corners. Vertical sash to be counter balanced 3/16" tempered safety glass with chemical resistant non-metallic PVC framing, track, and aerodynamic sash lift. A sash stop is installed at the 1/2 open position. Vapor proof LED light fixture and control switch are wired to a single point junction box, 115/60Hz. AC All electrical components are U.L. listed. Fume hood is U.L.1805 classified	30"	45421	45521	45621	45821
	36"	45431	45531	45631	45831
<b>2. UniFlow SE AireStream VAV Fume Hood:</b> Same as #1 above except equipped with Variable Air Volume VAV restricted bypass feature in place of CAV bypass feature. Ducting must be connected to optional VAV exhaust system controls.	30"	45422	45522	45622	45822
	36"	45432	45532	45632	45832
<b>3. UniFlow SE AireStream Fume Hood with Explosion-Proof Light:</b> Same as #1 above except, equipped with explosion proof vapor tight light fixture. Class I Div II Group A B C & D, Class II Div II Group F & G, 115/230V, 50/60Hz U.L. listed fixture is installed but not wired. Must be field wired to comply with codes. Optional explosion proof switches, receptacles see page 12.	30"	45423	45523	45623	45823
	36"	45433	45533	45633	45833
<b>4. UniFlow SE AireStream Fume Hood International Configuration:</b> Same as #1 above except equipped to comply to international electrical configuration. 220V/50Hz AC Optional international electrical configuration, electrical switches, other receptacles see page 12.	30"	45424	45524	45624	45824
	36"	45434	45534	45634	45834
<b>5. Horizontal Sliding Sash Option: Add suffix to number above</b>		45HS-4	45HS-5	45HS-6	45HS-8
<b>6. Combination Sliding Sash Option: Add suffix to number above</b>		45CS-4	45CS-5	45CS-6	45CS-8

**CLASSIFIED** U.L., Underwriters Laboratory U.L.1805 for fume hoods & cabinets. This classification covers construction, materials, flammability, & 1805 containment. U.L. 3101 electrical performance is tested using HIPOT testing, (high potential high voltage). HEMCO's test facility is compliant to test fume hoods for U.L. 1805 Classification.

UniFlow SE AireStream Hood Dimensions				
Hood Width "A"	48"	60"	72"	96"
Interior Width "C"	38"	50"	62"	86"
Diameter "D"	12"	12"	12"	(2) 12"

CAV Fume Hood Face Velocity				
The recommended face velocity for efficiency & safety is 80-100 FPM. Lower face velocity may compromise user safety.				
Sash in full open position should be for setup of apparatus & maintenance service only. Design opening is at 1/2 open at 100 FPM (feet per minute), face velocity at full open would be approximately 50 FPM.				
Sash Management & Design				
Size Hood	48"	60"	72"	96"
1/2 Open CFM	385	474	592	800
1/2 Open Static Pressure	.15	.25	.20	.20
Full Open CFM	773	938	1162	1613

**Sash Stop** located at 1/2 open position to reduce air flow volume 50%, provides best possible user protection and safety. **Cat. No. 51651** (standard on SE, LE & CE AireStream fume hoods)

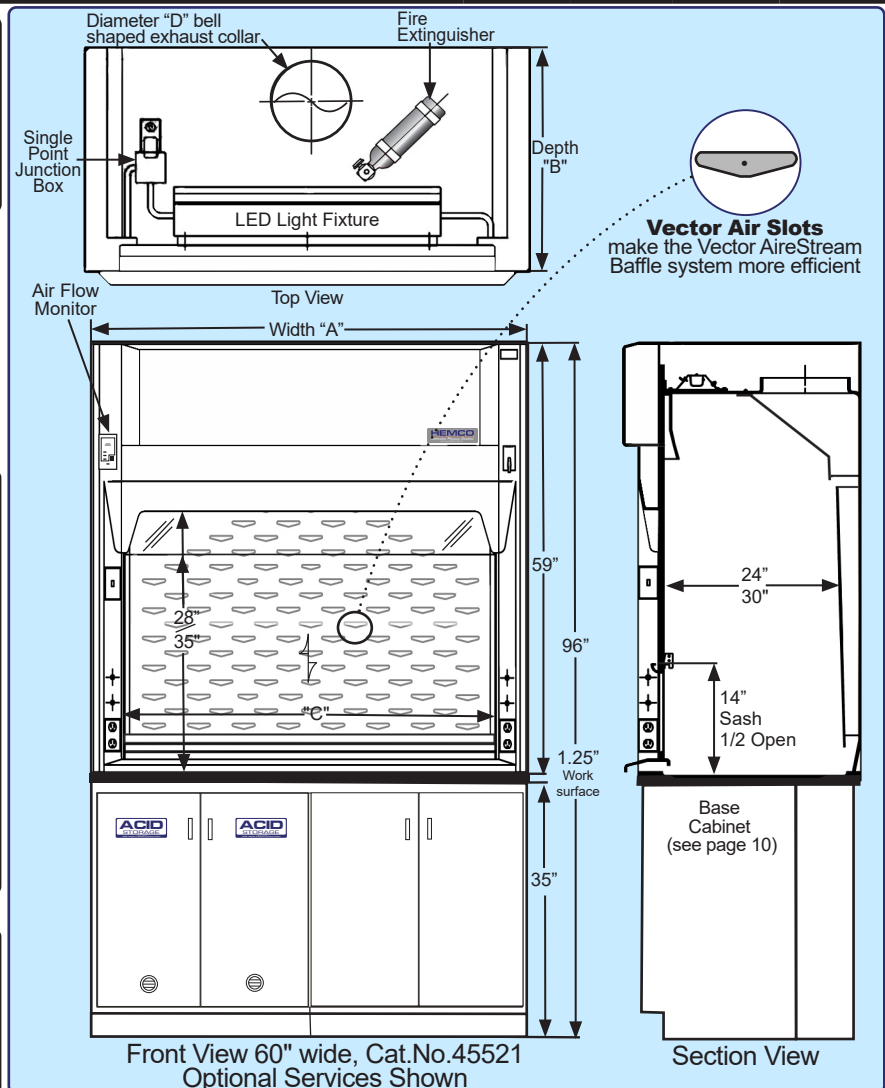

# UniFlow LE AireStream Fume Hoods

High efficiency, full duty fume hood in 36", 48", 60", 72" and 96" widths. UniFlow LE AireStream Fume Hoods are low flow constant volume for energy savings & maximum user protection. The aerodynamic face opening with airfoil provides uniform air flow through the fume chamber. The Vector Baffle System directs the air through the fume chamber to the bell shaped exhaust collar with minimum turbulence. Requires Remote Exhaust Blower. Fume hood is U.L.1805 classified.



**UniFlow LE AireStream Hood Cat. No. 35461** shown with optional epoxy resin work surface, base cabinet and fixtures See pages 10-14 for accessories.

**UniFlow Superstructure** non-metallic construction, total chemical and corrosion resistance, superior durability and long life. Interior fume chamber one-piece glass smooth, all covered corners for ease of cleaning. Unitized construction reduces weight for ease of installation. Includes 5 year warranty.

## UniFlow AireStream Vector Baffle

System Features Vector Air Flow Slots for low flow and high performance. Maintains uniform air flow thru the baffle system to bell shaped exhaust collar outlet.

**Access Panel** removable to access ducting connections, plumbing & electrical services from a single point electrical box, 115/60Hz AC operation.

**Vapor Proof LED light fixture** polished stainless steel reflectors, and light switch on left column, all factory installed. Energy efficient 15W, 50/60Hz, 100-277VAC. 5 Year warranty. U.L. Listed

**28" Vertical Sash Height** provides ease of access for apparatus set-up in fume chamber. Sash is perfectly counter balanced, 3/16 tempered safety glass, coated stainless steel cable with stainless steel pulley assembly. Framed in nonmetallic PVC framing, track, and aerodynamic sash lift for ease of movement & air flow efficiency. Standard Sash.

**32" Viewing Height** interior fume chamber with 24" or 30" interior reach in depth. With 54" interior working height, allowing for tall apparatus and distillation grid.

**Angled Picture Frame Opening** the aerodynamic face opening with air foil provides uniform air flow into the fume chamber and thru the Vector AireStream Baffle System.



**Air Flow Monitor** (Optional equipment) continuously monitors face velocity air flow, meets ANSI and OSHA requirements.

**Cat. No. 51403** (see page 39)

## SASH OPTIONS

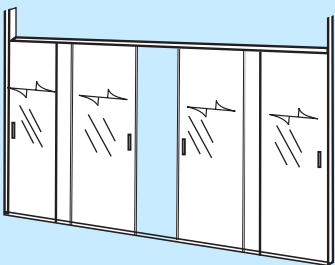

**Horizontal Sashes**  
Max opening is 50%, (4) panels on (2) tracks, conveniently lift out for equipment set-up or cleaning. For 50% reduction of air supply.

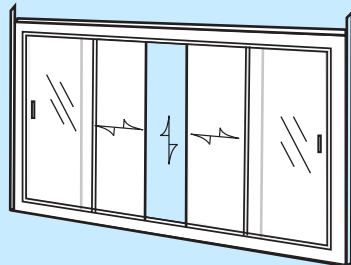

**Combination Horizontal / Vertical Sash** Offers the advantages of both sash types. Horizontal sash offer energy savings while vertical option allows full access to the fume chamber. Frame is of type 304 stainless steel. (see page 6 number 6)

## 72" CAV Fume Hood vs 72" VAV Fume Hood

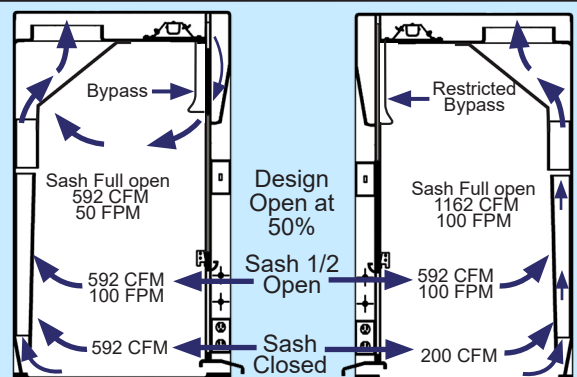

- The CAV with Constant Volume exhaust blower (592 CFM), maintains 100 FPM face velocity at 1/2 open design position.
- The VAV fume hood would need to be equipped with a variable volume exhaust system to maintain 100 FPM at any sash opening height.



# UNIFLOW LE AireStream Fume Hoods

UNIFLOW LE AIRESTREAM DESCRIPTIONS	Fume Hood Width "A"				
	36" Cat.No.	48" Cat.No.	60" Cat.No.	72" Cat.No.	96" Cat.No.
<b>1. UniFlow LE AireStream CAV Fume Hood:</b> Air Bypass low flow, constant air volume hood. Dual wall unitized construction, all non-metallic corrosion and fire resistant composite fiberglass construction. Molded one-piece fume chamber with white glass-smooth surface with all covered corners. Vector AireStream Baffle System and bell shaped exhaust collar. Sash to be counterbalanced, 3/16" tempered safety glass with chemical resistant non-metallic PVC framing, track & aerodynamic sash lift. A sash stop is installed at the 1/2 open position. Vapor proof LED light fixture and control switch are wired to a single point junction box, 115/60Hz, AC. All electrical components are U.L. listed. Optional electrical services see page 12. Fume hood is U.L.1805 classified.	35361	35461	35561	35661	35861
<b>2. UniFlow LE AireStream VAV Fume Hood:</b> Same as #1 above except equipped with Variable Air Volume VAV restricted bypass feature, in place of CAV bypass feature. Ducting must be connected to optional VAV exhaust system & controls.	35362	35462	35562	35662	35862
<b>3. UniFlow LE AireStream Fume Hood with Explosion-Proof Light:</b> Same as #1 above except, equipped with explosion proof vapor tight light fixture. Class I, Div II, Group A B C & D. Class II Div II Group F & G 115/230V, 50/60Hz, U.L. listed fixture is installed but not wired. Must be field wired to comply with codes. Optional explosion proof electrical services.	35363	35463	35563	35663	35863
<b>4. UniFlow LE AireStream Fume Hood International Configuration:</b> Same as #1 above except equipped to comply with optional CE international electrical configuration. 220V/50Hz AC. Electrical services see page 12, exhaust blowers available.	35364	35464	35564	35664	35864
<b>5. Horizontal Sliding Sash Option: Add suffix to number above.</b>	NA	35HS-4	35HS-5	35HS-6	35HS-8
<b>6. Combination Sliding Sash Option: Add suffix to number above</b>	NA	35CS-4	35CS-5	35CS-6	35CS-8

**CLASSIFIED** U.L., Underwriters Laboratory U.L.1805 for fume hoods & cabinets. This classification covers construction, materials, flammability, & containment. U.L. 3101 electrical performance is tested using HIPOT testing, (high potential high voltage). HEMCO's test facility is compliant to test fume hoods for U.L. 1805 Classification.

Width "A"	36"	48"	60"	72"	96"
Width "C"	25"	37"	49"	61"	85"
Diameter "D"	8"	10"	10"	12"	(2)10"

**CAV Fume Hood Face Velocity**  The recommended face velocity for efficiency & safety is 80-100 FPM. Lower face velocity may compromise user safety. Sash in full open position should be for setup of apparatus & maintenance service only. Design opening is at 1/2 open at 100 FPM (feet per minute), face velocity at full open would be approximately 50 FPM.

Size Hood	36"	48"	60"	72"	96"
1/2 Open	241	385	474	592	800
1/2 Open Static Pressure	.04	.06	.10	.13	.08
Full Open	438	773	938	1162	1613

**Sash Stop** located at 1/2 open position to reduce air flow volume 50%, provides best possible user protection and safety. **Cat. No. 51651**  (standard on SE, LE & CE AireStream fume hoods)

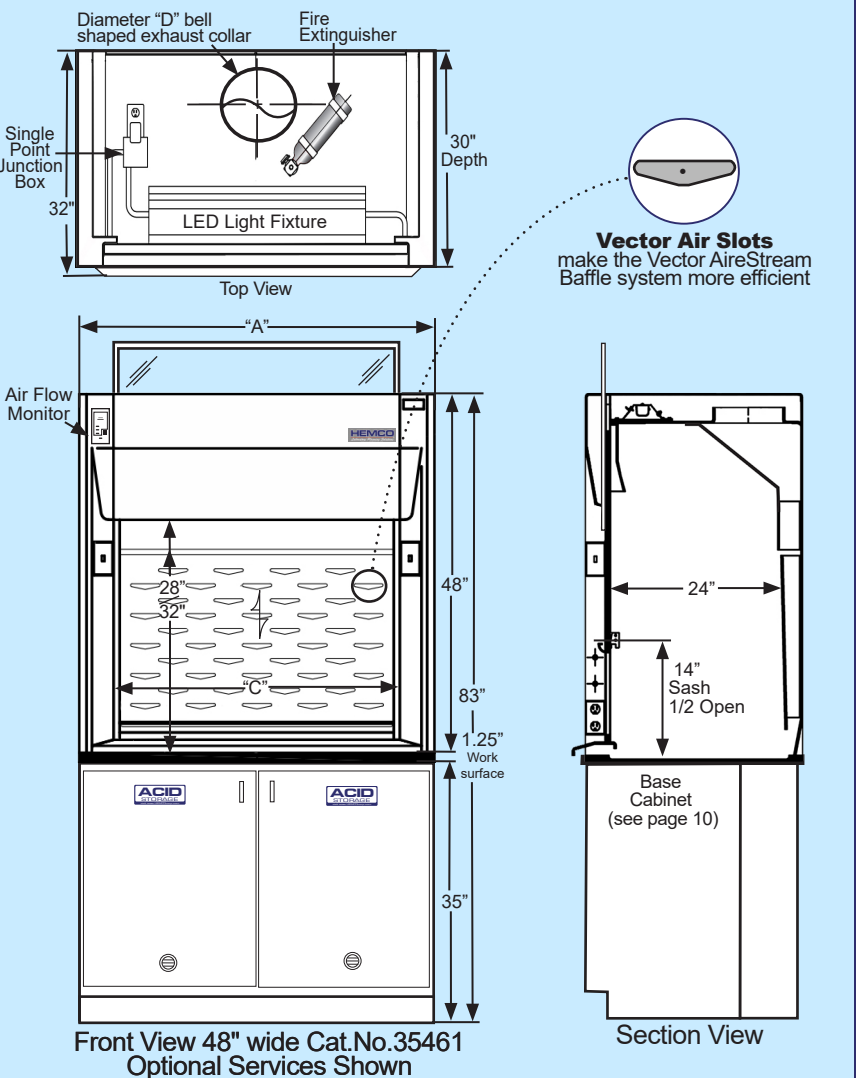

# UniFlow<sup>®</sup> CE AireStream Fume Hoods

Full duty fume hoods in space and energy saving sizes of 30", 36", 48", & 72" widths. UniFlow CE AireStream models are low flow constant volume fume hoods that require no VAV controls, no motorized baffles, no costly auxiliary air system and no special integral supply fans. These units can save 50% or more in costly exhaust volume typically required to operate a conventional fume hood. Requires Remote Exhaust Blower. Fume hood is U.L.1805 classified.



**UniFlow CE AireStream Hood**  
**Cat. No. 13641** shown with optional base cabinet, worksurface and fixtures See pages 10-14 for accessories.

**UniFlow Superstructure** non-metallic construction, total chemical and corrosion resistance, superior durability and long life. Interior fume chamber one-piece glass smooth, all coved corners for ease of cleaning. Unitized construction reduces weight for ease of installation. Includes 5 year warranty.

**UniFlow AireStream Vector Baffle System** Features Vector Air Flow Slots for low flow and high performance. Maintains uniform air flow thru the baffle system to bell shaped exhaust collar outlet.

**Access Panel** removable to access ducting connections, plumbing & electrical services from a single point electrical box, 115/60Hz AC operation.

**Vapor Proof light fixture** with glass globe and light switch on left column, all factory installed. Energy efficient 15W, 50/60Hz, 100-277VAC. 5 Year warranty. U.L. Listed

**23" Vertical Sash Height** provides ease of access for apparatus set-up in fume chamber. Sash is perfectly counter balanced, 3/16 tempered safety glass, coated stainless steel cable with stainless steel pulley assembly. Framed in non-metallic PVC framing, track, and aerodynamic sash lift for ease of movement and air flow efficiency.

**27" Viewing Height** interior fume chamber with 19" interior reach in depth. 35" interior working height, allowing for tall apparatus and distillation grid.

**Angled Picture Frame Opening** the aerodynamic face opening with air foil provides uniform air flow into the fume chamber and thru the Vector AireStream Baffle System.

**Air Flow Monitor** (Optional equipment) continuously monitors face velocity airflow, meets ANSI and OSHA requirements.  
**Cat. No. 51403** (see page 39)

FUME HOOD ACCESSORIES	
<p><b>Fume Hood Worksurfaces</b>            A complete line of worksurfaces, available in Composite Resin, Phenolic Resin, and Stainless steel. (see page 8)</p>	<p><b>Fume Hood Cabinets</b>            Constructed of 18 gauge furniture grade steel, powder coated color white. Base cabinets have a load capacity of 500 pounds per linear foot. Tested to be SEFA 8 Compliant.(see page 10)</p>

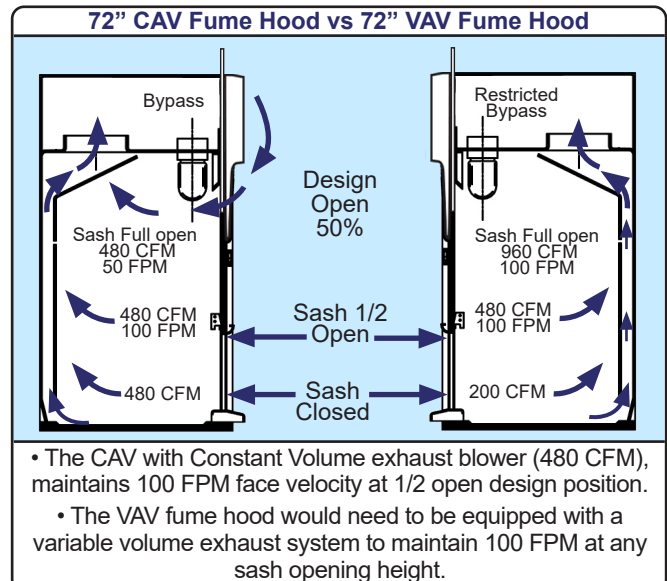



# UNI-FLOW<sup>®</sup> CE AireStream Fume Hoods

UNIFLOW CE AIRESTREAM DESCRIPTIONS	Fume Hood Width "A"			
	30" Cat.No.	36" Cat.No.	48" Cat.No.	72" Cat.No.
<b>1. UniFlow CE AireStream CAV Hood with Vapor Proof Light:</b> The unitized superstructure features a molded seamless fume chamber with all corners covered. Manufactured of flame retardant chemical resistant composite resin using a minimum of metallic parts. Viewing sash is constructed of 3/16" clear tempered safety glass with frame and track fabricated of chemical resistant PVC. Equipped with Vector AireStream Baffle System to efficiently direct air through the fume chamber. Baffle is easily removed for cleaning. Vapor proof light fixture with column mounted light switch. All electrical services are U.L. & C.S.A listed and factory wired to a single point junction box, 115/60Hz. Hood is shipped completely assembled. Optional electrical services see page 12.	13041	13641	14841	17241
<b>2. UniFlow CE AireStream VAV Fume Hood:</b> Same as #1 above except equipped with Variable Air Volume VAV restricted bypass feature, in place of CAV bypass feature. Ducting must be connected to optional VAV exhaust system & controls.	13045	13645	14845	17245
<b>3. UniFlow CE AireStream Hood with Explosion-Proof Light:</b> Same as #1 above except, equipped with explosion proof vapor tight light fixture. Class I, Div II Group A,B,C & D. Class II Div II Group F, & G, 115/230V, 50/60Hz, U.L. listed fixture is installed but not wired. Must be field wired to comply with codes. Optional explosion proof switches, receptacles see page 12, and exhaust blowers are available.	13043	13643	14843	17243
<b>4. UniFlow CE AireStream Fume Hood International Configuration:</b> Same as #1 above except equipped to comply with optional CE international electrical configuration. 220V/50Hz AC. Electrical services see page 12, exhaust blowers available.	13046	13646	14846	17246
<b>5. Composite Resin Worksurface:</b> 1.25" thick, color: gray, dished, factory installed	13017	13617	14817	17217
<b>6. Phenolic Worksurface:</b> 1.25" thick, color: black, dished	13028	13628	14828	17228
<b>7. Stainless Steel Worksurface:</b> 1.25" thick, color: stainless steel	13016	13616	14816	17216

**CLASSIFIED**  
 U.L., Underwriters Laboratory U.L.1805 for fume hoods & cabinets. This classification covers construction, materials, flammability, & containment. U.L. 3101 electrical performance is tested using HIPOT testing, (high potential high voltage). HEMCO's test facility is compliant to test fume hoods for U.L. 1805 Classification.

**UniFlow CE AireStream Hood Dimensions**

Width "A"	30"	36"	48"	72"
Width "C"	23.5"	28.5"	40.5"	64.5"
Diameter "D"	4"	6"	8"	10"

**CAV Fume Hood Face Velocity**   
 The recommended face velocity for efficiency & safety is 80-100 FPM. Lower face velocity may compromise user safety. Sash in full open position should be for setup of apparatus & maintenance service only. Design opening is at 1/2 open at 100 FPM (feet per minute), face velocity at full open would be approximately 50 FPM.

Sash Management & Design				
Size Hood	30"	36"	48"	72"
1/2 Open CFM	189	230	327	480
1/2 Open Static Pressure	.04	.06	.10	.13
Full Open CFM	378	460	654	960

**Sash Stop** located at 1/2 open position to reduce air flow volume 50%, provides best possible user protection and safety. **Cat. No. 51651**  
 (standard on SE, LE & CE AireStream fume hoods)

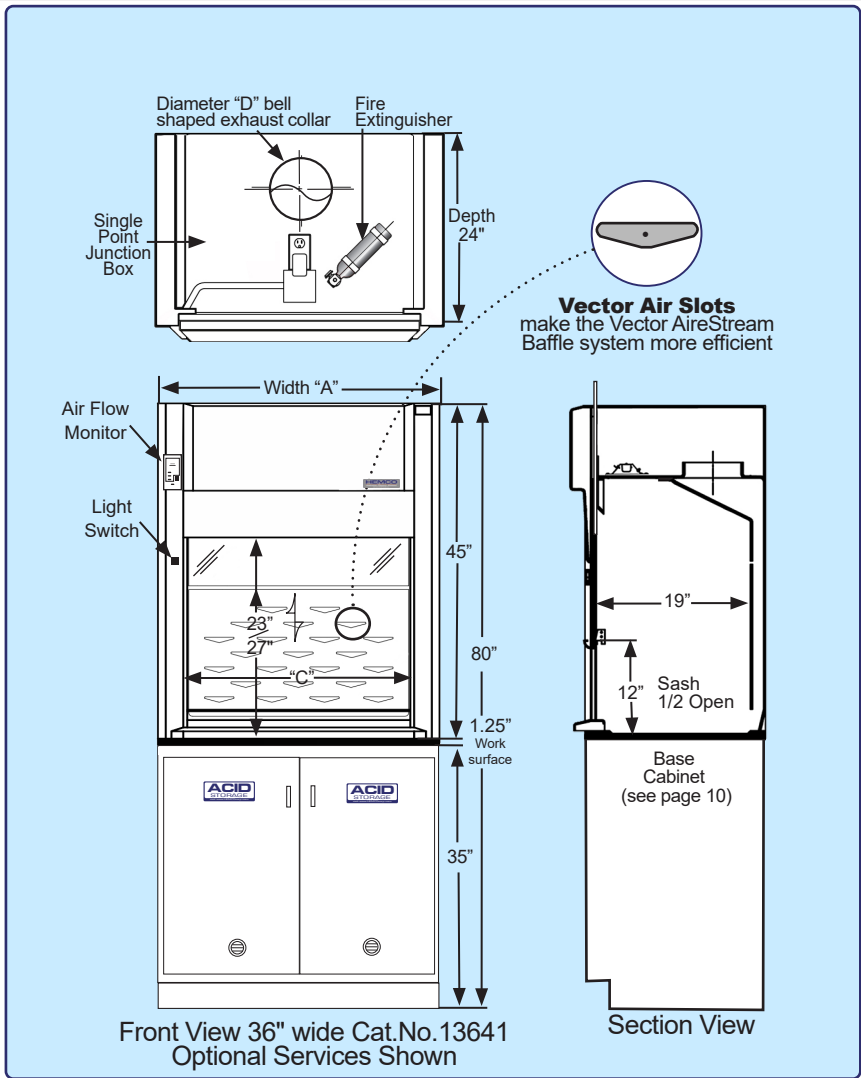
# HEMCO Plan-A-Hood Worksheet

The Following is a sample of the UniFlow SE AireStream Plan-A-Hood Worksheet, Plan-A-Hood Worksheets are also available for LE and CE AireStream fume hoods. To access go to [www.HEMCOcorp.com](http://www.HEMCOcorp.com) select the model and click on the Plan-A-Hood link.

UNIFLOW FUME HOOD	QTY	CAT. NO.
AIR BY PASS / CAV		
CONVENTIONAL / VAV		
AUXILIARY AIR		
DISTILLATION		
RADIOISOTOPE		
PERCHLORIC ACID		
ADA		

AIR FLOW MONITOR	QTY	CAT. NO.
DIGITAL		
ANALOG		
OTHER		

SASH	QTY	CAT. NO.
VERTICAL MOVING STD		
HORIZONTAL MOVING		
COMBINATION H&V		

SASH STOP	QTY	CAT. NO.
SPECIFY LOCATION		

PLUMBING SERVICES*	QTY	CAT. NO.
SERVICE SET OF FOUR		

\*SPECIFY AIR,GAS,VAC,C/W OR OTHER

ELECTRICAL SERVICES	QTY	CAT. NO.
DUPLEX RECEPT. 125V, 15A		
DUPLEX RECEPT. 125V, 20A		
SIMPLEX RECEPT. 250 V		
DUPLEX GFI 125V, 15A		
DUPLEX GFI 125V, 20A		

ACCESS PANEL	QTY	CAT. NO.
INSIDE LOCATION		
OUTSIDE LOCATION		

CABINETS	QTY	CAT. NO.
SINK CABINET		
BASE CABINET		
ACID CABINET		
FLAMMABLE CABINET		

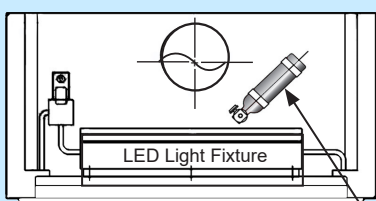

UniFlow SE AireStream

LED Light Fixture

TOP VIEW

Fill out this form and email to:  
[info@hemcocorp.com](mailto:info@hemcocorp.com)

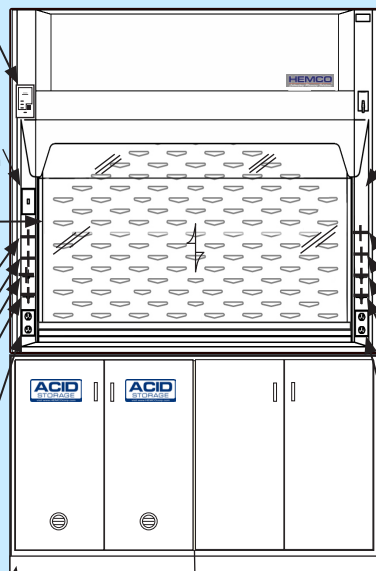

FRONT VIEW WITH BASE CABINET

Optional services shown  
(see 11 for service options)

Service Slot

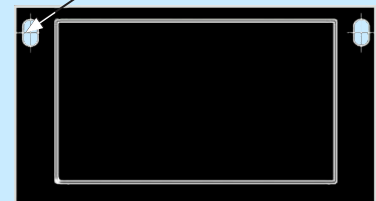

PLAN VIEW OF WORKSURFACE  
(see page 10 for worksurfaces)

CUSTOMER NOTES
✓ LABORATORY FUME HOODS
✓ CASEWORK
✓ WORKSURFACE
✓ LABORATORY FUME HOOD
✓ SPECIFY HEMCO

FIRE EXTINGUISHER	QTY	CAT. NO.
20 SQ FT DRY CHEMICAL		
30 SQ FT DRY CHEMICAL		
50 CU FT HALON		
125 CU FT HALON		

BLOWER SWITCH	QTY	CAT. NO.
TOGGLE SWITCH 125V, 15A		
TOGGLE SWITCH 125V, 20A		
TOGGLE SWITCH. 250V, 20A		
TOGGLE SWITCH W/PILOT		
MOTOR STARTER SWITCH		

PLUMBING SERVICES*	QTY	CAT. NO.
SERVICE SET OF FOUR		

\*SPECIFY AIR,GAS,VAC,C/W OR OTHER

ELECTRICAL SERVICES	QTY	CAT. NO.
DUPLEX RECEPT. 125V, 15A		
DUPLEX RECEPT. 125V, 20A		
SIMPLEX RECEPT. 250 V		
DUPLEX GFI 125V, 15A		
DUPLEX GFI 125V, 20A		

ACCESS PANEL	QTY	CAT. NO.
INSIDE LOCATION		
OUTSIDE LOCATION		

WORKSURFACE	QTY	CAT. NO.
EPOXY RESIN		
PHENOLIC RESIN		
304 STAINLESS STEEL		

**Questions / Ready to order**  
Call 1-800-779-4362

This is page 1 of 2, to see all Plan-A-Hood work sheets go to [www.HEMCOcorp.com](http://www.HEMCOcorp.com) select the model & click on Plan-A-Hood

Standard Color is Lab White, other colors are available.

Lab White - 01	Silver Beige - 02	Pewter Gray - 03	Zircon Blue - 04



# SE & LE Fume Hood Worksurfaces & Base Cabinets

A complete line of worksurfaces and cabinets to suit any application from economical light duty to heavy acid and solvent use. Select the worksurfaces and cabinets that meet your laboratory's requirements. Standard sizes are listed below. HEMCO's technical staff can make recommendations to suit your specific needs.

## (UniFlow SE, LE hoods only) Epoxy Resin, color: black, 1-1/4" thick, .375" dished



Epoxy Resin Worksurfaces are recommended for general laboratory work where greater chemical resistance is required. Surface is dished 3/8" to contain spillage. Worksurface is cast of thermosetting epoxy resin, creating a molded solid 1-1/4" thick top which is extremely hard, abrasion and heat resistant. Tested to UL 1805 classification.

Size	Cat. No.	Size	Cat. No.
36"W x 30"D	20315	36"W x 36"D	20325
48"W x 30"D	20415	48"W x 36"D	20425
60"W x 30"D	20515	60"W x 36"D	20525
72"W x 30"D	20615	72"W x 36"D	20625
96"W x 30"D	20815	96"W x 36"D	20825

## (UniFlow SE, LE) Phenolic Resin, color: black, 1-1/4" thick

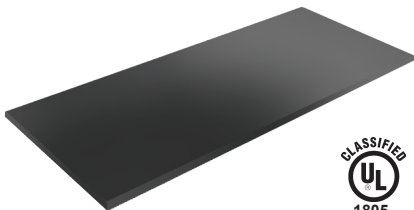

Phenolic Resin Worksurfaces are recommended for general laboratory work where high concentrations of solvent, acids and alkalis are being worked with. Work surface combines excellent chemical resistance scratch and wear resistance. Surface is flat 1-1/4" thick. Tested to UL 1805 classification.

Size	Cat. No.	Size	Cat. No.
36"W x 30"D	21428	36"W x 36"D	22428
48"W x 30"D	21418	48"W x 36"D	22418
60"W x 30"D	21518	60"W x 36"D	22518
72"W x 30"D	21618	72"W x 36"D	22618
96"W x 30"D	21818	96"W x 36"D	22818

## (UniFlow SE, LE hoods only) Stainless Steel, satin finish, 1-1/4" edge, .375" dished

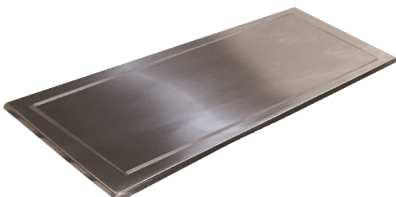

**Stainless Steel Fume Hood Worksurfaces** are fabricated of type 304, 16 gauge steel with #3 satin finish. Surface is dished 3/8" to contain spillage. All corners, ends, and joints are continuous 1-1/4" heliarc welded and ground smooth. **Type 316 stainless steel is also available.**

Size	Cat. No.	Size	Cat. No.
36"W x 30"D	20316	36"W x 36"D	20326
48"W x 30"D	20416	48"W x 36"D	20426
60"W x 30"D	20516	60"W x 36"D	20526
72"W x 30"D	20616	72"W x 36"D	20626
96"W x 30"D	20816	96"W x 36"D	20826

## Fume Hood Base Cabinets & Tables



Casework is tested to be SEFA 8 compliant. See page 48. Standard cabinets and tables are 35" high and 22" deep. For 36" wide use (1) 36", for 48" wide (1) 48", for 60" wide (2) 30", for 72" wide (2) 36", For 96" wide (2) 48". Standard color is White, Optional Silver Beige, Pewter Gray, or colors to your specifications.

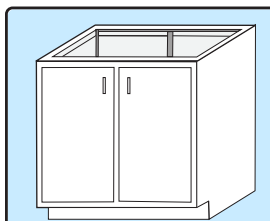

**Base Cabinet**  
Constructed of furniture grade steel. With adjustable shelf and levelers. Standard depth is 22", standard height is 36". Standard color: white (see page 48)

Width	Doors	Cat. No.
30"	2	53011
36"	2	53611
48"	2	54811
60"	2	56011

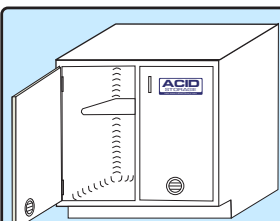

**Acid Cabinet** Interior is lined with one piece acid resistant white composite resin liner and all coved corners, for superior corrosion resistance, with vents and fixed shelf. Standard depth is 22", standard height is 36". (see page 48)

Width	Doors	Cat. No.
30"	2	15300
36"	2	15360
48"	2	15480
Vent Kit	---	81000

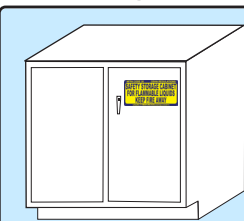

**Flammable Cabinet** provides safe storage of flammables. Color: silver beige. Constructed of welded double wall furniture grade steel. Cabinet has an adjustable shelf and locking hinged doors. Meets NFPA codes. Standard depth is 22", standard height is 36".

Width	Doors	Cat. No.
30"	2	18300
36"	2	18030
48"	2	18040
Vent Kit	--	81000

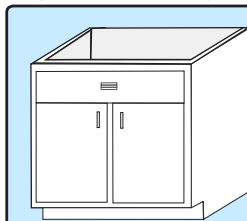

**Sink Unit Cabinet**  
Constructed of furniture grade steel. Cabinet has hinged doors and levelers. Standard depth is 22", standard height is 36". See page 15 for sinks. (see page 48)

Width	Doors	Cat. No.
30"	2	71811
36"	2	71812
48"	2	71814
60"	2	71815

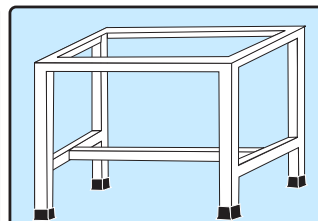

**Fume Hood Base Table**  
Heavy duty, all welded 2" square tube steel construction. Standard depth is 29". Each leg has levelers with fitted black boots. Available in, standard 35" bench height, & 28" sitting height. Standard color: white (see page 48)

Width	Std	Sitting
30"	53012	53032
36"	53612	53632
48"	54812	54832
60"	56012	56032
72"	57212	57232
96"	59612	59632

# Fume Hood Wall Mounted Plumbing Fixtures

Fume hood remote control service fixtures feature epoxy coated brass, chemical resistant, color-coded, serrated hose connections, and 3/8" NPT brass valves with rod and handle assembly. Plumbing fixtures are factory installed on hood, they can be pre-plumbed if specified. Please specify service required, fixture location, and inside or outside service access panels. Conforms to ANSI Z21.15.

Service Fixture Color Code Chart	Green - Cold Water	Red - Hot Water	Blue - Gas	Orange - Air
	Yellow - Vacuum	Brown - Nitrogen	Black - Steam	White - Deionized Water



## Service Set of Two (specify left or right mounting)

Two remote controlled service fixture set. Color-coded index buttons with matching color-coded serrated tip. Specify service required. Epoxy coated brass.

Cat. No. 50121-FS



## Service Set of Four (specify left or right mounting)

Four remote controlled service fixture set. Color-coded index buttons with matching color-coded serrated tip. Specify service required. Epoxy coated brass.

Cat. No. 50141-FS



## Service Set of Six (specify left or right mounting)

Six remote controlled service fixture set. Color-coded index buttons with matching color-coded serrated tip. Specify service required. Epoxy coated brass.

Cat. No. 50161-FS



## DI Faucet

Pure water 6" rigid PVC goose neck. Cat. No. 50019



## DI Faucet

Pure water 6" swivel tin-lined gooseneck. Epoxy coated brass. Cat. No. 50022



## Gooseneck PVC Service Fixture

Wall mount, no valve, constructed of PVC. Cat. No. 51110



## Service Fixture

Cold water, remote controlled epoxy coated brass turret. Cat. No. 50012



Water Faucet with Vacuum Breaker Cold water 6" swivel gooseneck. Epoxy coated brass. Cat. No. 50023

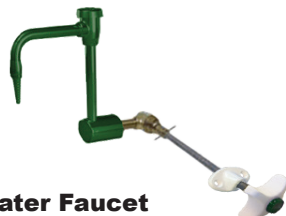

## Water Faucet with Vacuum Breaker

Cold water remote controlled 6" swivel gooseneck. Turret & gooseneck are epoxy coated brass. Cat. No. 50113-CW



## Water Faucet

Cold water remote controlled 6" swivel gooseneck. Turret and gooseneck are epoxy coated brass. Cat. No. 50112-CW



## Service Fixture

Remote controlled single service outlet. color-coded index buttons with matching color coded serrated tip outlets. Cat. No. 50013



## Base Fixture

Deck or wall mount, 3/8 NPT remote, no valve. PVC. Cat. No. 51013



## PVC Lab Turret

Deck or wall mount, 3/8 NPT, no valve, PVC. Cat. No. 51012



## Mix Faucet

Hot and cold remote controlled 6" swivel gooseneck. Turret and gooseneck are epoxy coated brass. Cat. No. 50102



## Mix Faucet

Hot and cold water remote controlled turret. Turret is of epoxy coated brass. Cat. No. 50101



## High Flow Water Valve, Straight Pattern

Ball valve construction with quarter turn open / close, used for supply and return connections. Cat No. 51023



## Single Keycock

Single flange mounted needle valve, keycock with integral flange and shank connection. Epoxy coated brass. 3/8" NPT with lock nut. Single Cat. No. 50025 Double Cat. No. 50125



## Aspirator

3/8" NPS male inlet Epoxy coated brass. Cat. No. 50058



## External Mounted Vacuum Breaker

Breaker with 3/8" IPS inlet and outlet. Chrome plated brass. Cat. No. 50044



# Fume Hood Electrical Services

Electrical services are UL, CSA & CE listed. They come factory installed, wired to a single point junction box when ordered with fume hoods. Services must be wired to comply with local codes.

## Fume Hood Electrical Services (UL)



**Duplex Receptacle**  
115V single phase receptacle. Installed on front column of fume hood. Includes junction box and cover plate. UL listed.

amps	Cat. No.
15 amps	50029-1
20 amps	50029-2



**Single Receptacle**  
230V single phase receptacle. Installed on front column of fume hood. Includes junction box and cover plate. UL listed.

amps	Cat. No.
15 amps	50030-1
20 amps	50030-2



**GFI Duplex**  
115V consists of combination ground fault interrupters, 3-wire polarized grounded. Includes junction box & cover plate. UL listed.

amps	Cat. No.
15 amps	50048-1
20 amps	50048-2



**Data Port**  
Cat 6, 10 gigabit ethernet, (2) port fixture. Installed on front column. Cabling not included.

Cat No. 50053



**Light Switch (standard)**  
115V/15 amps. Includes junction box and cover plate. UL listed.

Cat. No. 50028-1



**Blower Switch with Pilot Light**  
Includes junction box and cover plate. UL listed.

volts/amps	Cat. No.
115V 15 amps	50027-1
230V 20 amps	50027-3



**Blower Switch**  
Mounted in a single gang receptacle box with face plate. Factory mounted not wired. Includes thermal overload protection. Double pole switch for up to 1 HP, single phase, 60 Hz 115V 50 Hz, 230V AC motors. UL listed.

Cat. No. 50050



### Service Port Pass-Through

Convenient port allows cords, tubes, or cables to pass to and from the hood.

Cat. No. 50100

## Fume Hood Vapor Proof Light Fixtures (UL)



**Vapor-Proof Light**  
Factory installed. Accepts bulb up to 150w, 115V, & LED UL listed, (bulb not included) Standard on CE, Canopy, Universal and EcoFlow hoods.

Cat. No. 50035

### Vapor Proof LED Light Fixture



LED fixture with Stainless steel reflector, (2) tube, 115V, UL listed. (LEDs included) LED has a 50,000 hour average life span. Standard on SE and LE Fume hoods.

24 inch.....	Cat. No. 51124
36 inch.....	Cat. No. 51136
48 inch.....	Cat. No. 51148

### Fluorescent Lighting



T-5 fixture with Stainless steel reflector, (2) tube, 115V/230V tubes changed from the outside. (fluorescent tubes are included) UL listed. Optional on SE and LE Fume hoods.

24 inch.....	Cat. No. 50224
36 inch.....	Cat. No. 50236
48 inch.....	Cat. No. 50248

## Fume Hood Explosion Proof Light Fixtures and Services (UL)



**Explosion-Proof Light Std Class I Div II**  
For use in hazardous locations. Gray, two-coat epoxy finish with easily removed prismatic globe. Factory mounted, not wired. Accepts compact fluorescent or LED, (bulb not included) 115V /230V UL listed. Class I Div II Group A, B,C,D Class II Div II Group F & G

Cat. No. 50034



**Explosion-Proof Fixture Class I Div I**  
For use in hazardous locations. Gray, two coat epoxy finish with easily removed prismatic globe. Accepts compact fluorescent or LED, (bulb not included) 115V/230V. Factory mounted, not wired. UL listed. Class I Div I Group C, D, Class II Div I Group E, F & G

Cat. No. 50038



**Explosion-Proof Fluorescent Lighting Class I Div I**  
fixture is (2) tube, 115V/230V with tubes changed from the outside. UL listed. (fluorescent tubes are included)

24 inch..... Cat. No. 50077  
48 inch..... Cat. No. 50078



**Explosion-Proof Switch Class I Div I or II**  
For use in hazardous locations. Surface mount type with cast aluminum housing. Specify 115V/20 amp or 230V/20 amp. UL listed.

Cat. No. 50036



**Explosion-Proof Plug Class I Div I or II**  
Adaptable for use with all receptacles. 3-pole, 2-wire, Specify 115V/20 amp or 230V/20 amp AC. Not installed at factory. UL listed.

Cat. No. 50039



**Explosion-Proof Receptacle Class I Div I or II**  
For use in hazardous locations. Surface mount type with aluminum housing, 3-pole, 2-wire, Specify 115V/20 amp or 230V/20 amp. Not installed at factory. UL listed.

Cat. No. 50037



**Explosion-Proof Ground Fault Interrupter**  
For use in hazardous locations. Factory sealed GFI is designed to interrupt a circuit when a ground fault is detected. 115V 60 Hz, 20 amp. Not installed at factory. UL listed.

Cat. No. 50104

## Fume Hood International Electrical Services (CE)



**Continental European Socket with cover cap**  
Type: CEE7 color: gray Rating 250V/16 amp, installed at factory.

Cat. No. 50004



**Indian / South Africa Socket ISA**  
Type: BS546 color: white Rating 250V/15 amp, installed at factory.

Cat. No. 50006



**United Kingdom / Ireland Shuttered Socket**  
Type: BS1363 color: white Rating 250V/13 amp installed at factory.

Cat. No. 50007



**Continental European Panel Mount Socket**  
Type: CEE7 color: white Rating 250V/15 amp installed at factory.

Cat. No. 50008

# Fume Hood Sink and Plumbing Services

A complete line of sinks in epoxy resin, polypropylene, and stainless steel. We also offer a wide variety of plumbing accessories including neutralization tanks and bead baths. HEMCO welcomes the opportunity to quote your special applications. Additional sink sizes are available. Contact factory for more details. Conforms to ANSI Z21.15.

## Epoxy Resin Fume Hood Laboratory Sinks



**Epoxy Resin Sink** Laboratory sink made of chemical and corrosion resistant epoxy resin. Drop-in sink. color: black. Please specify desired location. Includes sink stopper & drain outlet.

	Size	Cat. No.
1	9" x 6" x 6" deep	42021
2	16" x 12" x 8" deep	42022
3	18" x 15" x 11" deep	42026
4	24" x 16" x 8" deep	42027

## Polypropylene Fume Hood Laboratory Sinks



**Polypropylene Sink** Laboratory sink made of chemical resistant heavy duty polypropylene. Drop-in sink. color: black. Please specify desired location. Includes drain outlet.

	Size	Cat. No.
1	12" x 8" x 8" deep	72041
2	14" x 10" x 6" deep	72043
3	18" x 15" x 12" deep	72045
4	28" x 20" x 9" deep	72048

## Stainless steel Fume Hood Laboratory Sinks



**Stainless Steel Sink** Laboratory sink made of one-piece, type 304 stainless steel and polished to a No. 4 satin finish. Drop-in sink. Underside is sound deadened to reduce drumming. Specify location. Includes drain outlet.

	Size	Cat. No.
1	12" x 12" x 7.5" deep	42031
2	16" x 16" x 7.5" deep	42032
3	16" x 22" x 7.5" deep	42033
4	16" x 28" x 7.5" deep	42034

## Fume Hood Cup Sinks & Plumbing Fixtures



**Cupsink 6" Diameter**

Cupsink is made of polyolefin with 1.5" IPS tailpiece and outlet strainer.  
Cat. No. 40118



**Oval Cup Sink**

Drop-in cup sink available in polyolefin. 1.5" IPS tailpiece includes strainer.

3" x 6"	40119
3" x 9"	40121



**Oval Wall Cupsink 6" x 3"**

Cupsink is made of polyolefin with 1.5" IPS tailpiece and outlet strainer.  
Cat. No. 40419



**Jar P Trap**

P-trap includes adjustable tailpiece and removable jar with 1.5" IPS tail piece.  
Cat. No. 40220



**P Trap**

P-trap is made of polypropylene with 1.5" IPS tailpiece.  
Cat. No. 40120

## Neutralization Tanks



Removable Lid

**15 gallon tank**

(17.25" dia. x 15.5" H with 1.5" IPS inlet / outlet)

Cat. No 40322

Note: 15 gallon tank requires (3) bags of limestone.

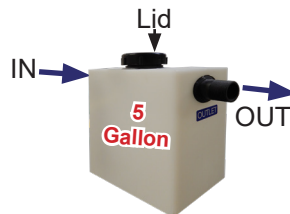

Lid

**5 gallon tank**

(5.5" wide x 14" deep x 20" high with 1.5" IPS inlet / outlet)

Cat. No 40222

Note: 5 gallon tank requires (1) bag of limestone.



**LIMESTONE**

**Limestone**

is utilized as the medium for neutralizing the hazardous waste. (50 lb bag)

Note: Limestone is not included with tank.

Cat. No. 40223

**Molded of one-piece, chemical resistant polyolefin Neutralization tanks are designed to dilute and neutralize laboratory waste and concentrated corrosives.**



# Apparatus Grids and Fire Extinguishers

Distillation apparatus grids are designed to mount small apparatus and glassware in the interior of the fume hood, maximizing the work area. Grids are available in aluminum, stainless steel, or fiberglass to meet specific needs. Mounting options: 1. Grids can be mounted to the side walls of the fume hood, 2. When more strength is required, grids can mount to both the sidewalls and the worksurface, consult factory for details.

## Fume Hood Apparatus Grids

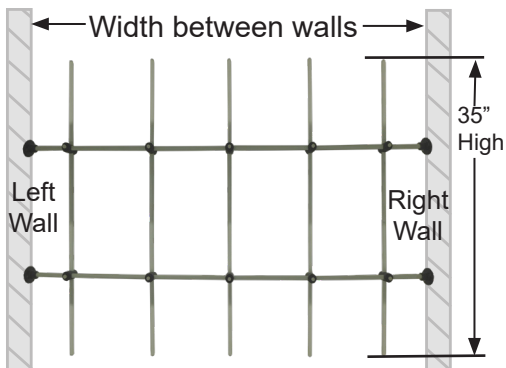

Fume hood with apparatus grid installed

Aluminum Apparatus Grid				
Fume Hood Width	48"	60"	72"	96"
Grid Width for Hood as Installed	36"	50"	62.5"	86.5"
Aluminum Rod Assembly 1/2" dia.	50141	50151	50161	50181

- All components are machined from solid aluminum bar stock.
- All aluminum lattice rod components are furnished with a satin (brushed) finish.
- Backing plates for hood wall and mounting screws for flanges are not included.

Stainless Steel Apparatus Grid				
Fume Hood Width	48"	60"	72"	96"
Grid Width for Hood as Installed	35"	46"	56"	81"
Stainless Steel Assembly 1/2" dia	50142	50152	50162	50182

- Stainless steel components offer superior strength and corrosion resistance for even the most demanding applications.
- All components are machined from Type 316 stainless steel bar stock and polished to a satin finish.
- Backing plates for hood wall and mounting screws for flanges are not included.

Non-Metallic Composite Apparatus Grid				
Fume Hood Width	48"	60"	72"	96"
Grid Width for Hood as Installed	35"	46"	56"	81"
Fiberglass Rod Assembly 1/2" dia.	50143	50153	50163	50183

- All rod components are white fiberglass.
- All connectors are molded in black nylon for strength and chemical resistance.
- Backing plates for hood wall and mounting screws for flanges are not included.
- Half open style clamps, facilitate adding or removing rods from existing assembly.

## Fire Extinguishers for Flammable Hazards in Fume Hood fume chamber

**Foremost: Fume hood fires must be extinguished promptly, failure to do so could result in loss of life and valuable equipment & processes. In case of a fire inside of a fume hood. 1. Lower the sash into the closed position. 2. Pull the manual front mount discharge cable to activate the fire extinguisher. 3. Shut off the fume hood blower on the fume hood, and any remote exhaust blowers that are connected. 4. Shut off any utility services that could feed a fire. Fire extinguisher activation occurs at 200° Fahrenheit. These are recommendations, contact your laboratory safety officer for guidelines.**



1. **7.5 Square Foot Fire Extinguisher** with automatic activation at 200° Fahrenheit. For fume hoods up to 60" wide. Up to 48" CE models.
  - With dry chemical for class ABC fires, 20 Square Feet.....**Cat No.**
  - With Halon, 20 Cubic Feet.....**Cat No.**
2. **20 Square Foot Fire Extinguisher** with automatic activation at 200° Fahrenheit. For fume hoods up to 60" wide. Up to 48" CE models.
  - With dry chemical for class ABC fires, 20 Square Feet.....**Cat No. 54020**
  - With Halon, 20 Cubic Feet.....**Cat No. 54120**
3. **30 Square Foot Fire Extinguisher** with automatic activation at 200° Fahrenheit. For fume hoods up to 60" wide. SE and LE models.
  - With dry chemical for class ABC fires, 30 Square Feet.....**Cat No. 54030**
  - With Halon, 30 Cubic Feet.....**Cat No. 54130**

**Note:** Larger models require (2) extinguishers, based on interior cubic dimensions.

# UniFlow<sup>®</sup> SE FM Floor Mount (Walk-In) Fume Hoods

UniFlow SE FM Floor Mounted (Walk-In) Hoods are ideally suited for synthesis and other rack type operations where tall apparatus is used or equipment is rolled into the work area. In widths 48", 60", 72", 96", 120" & 144" & depths of 30", 36", and 48". UniFlow Walk-In Hoods are available in standard or special sizes to meet various applications. Modular construction can be shipped disassembled for on-site assembly.



**UniFlow SE FM Hood 72" Cat. No. 11060**  
shown with vertical rising sash and optional worksurface.

**UniFlow Superstructure** to be non-metallic FRP composite construction for total chemical resistance, superior durability and long life. Interior fume chamber to be glass-smooth with Vector Baffle System & bell shaped exhaust collar. Modular construction reduces weight for ease of installation. Includes 5 year warranty.

## UniFlow AireStream Vector Baffle

System Features Vector Air Flow Slots for low flow and high performance. Maintains uniform air flow thru the baffle system to bell shaped exhaust collar outlet.

**Vapor Proof LED light fixture** polished stainless steel reflectors, and light switch on left column, all factory installed. Energy efficient 15W, 50/60Hz, 100-277VAC. 5 Year warranty. U.L. Listed

**High Efficiency** sash management provides for energy savings.

**User Protection** with sash in lowered position, fumes are kept safely away from the user.

**62" Sash Height** for viewing of fume chamber, loading and unloading equipment for set up. Includes upper and lower sash. 82" Stand Up Height for ease of access and interior depths of 24", 30", and 42" available.

## 70" Viewing Height Double Vertical Sash

provides ease of access for apparatus set-up in fume chamber. Sashes are perfectly counter balanced, 3/16 tempered safety glass, coated stainless steel cable with stainless steel pulley assembly. Framed in nonmetallic PVC framing, track, and aerodynamic sash lifts for ease of movement and air flow efficiency.

## Angled Picture Frame Opening

aerodynamic face opening with air foil provides uniform air flow into the fume chamber, & thru the Vector AireStream Baffle System, to the exhaust collar.

**Energy Efficient** vapor proof LED light fixture with polished stainless steel reflectors, and light switch on left column all factory installed.

**Plumbing Services** fixtures are color coded to specific service. (Optional equipment) (see page 11)

**Electrical Services** can be mounted on right or left side. (Optional equipment) (see page 12)



**Air Flow Monitor** (Optional equipment) continuously monitors face velocity air flow, meets ANSI and OSHA requirements.

**Cat. No. 51403** (see page 39)

## SASH OPTIONS

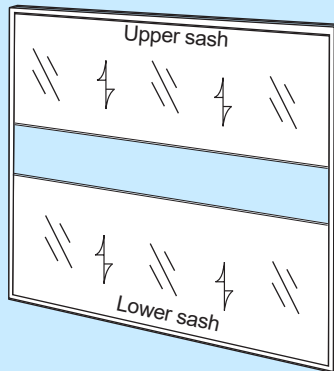

**VERTICAL SASHES** for HEMCO fume hoods, 4', 5', & 6' wide. The sash may be lifted to the completely open position for maximum access thru the fume chamber. Sash stops available.

**HORIZONTAL SASHES** for HEMCO fume hoods, 8', 10', & 12' wide. The maximum sash opening for the horizontal sash is 1/2 that of the vertical sashes. The smaller opening, means less air exhausted resulting in energy savings.



# UNI-FLOW SE FM Floor Mount (Walk-In) Fume Hoods

UNIFLOW SE FLOOR MOUNT DESCRIPTIONS	Fume Hood Width "A"						
	HOOD Depth "B"	48" Cat.No.	60" Cat.No.	72" Cat.No.	96" Cat.No.	120" Cat.No.	144" Cat.No.
<b>1. UniFlow SE Floor Mounted CAV Bypass Fume Hood with Vapor-Proof Light:</b> Superstructure to be modular composite chemical resistant FRP non-metal construction. Interior fume chamber to be glass-smooth with Vector Aire Stream Baffle System & bell shaped exhaust collar. Picture frame upper & lower sash opening with counter balanced sashes of clear tempered safety glass with chemical resistant PVC framing, track, and aerodynamic sash lift. Vapor proof LED light fixture & control switch are wired to a single point junction box, 115/60Hz, AC. All electrical components are U.L. listed. Horizontal sliding doors optional on 96" & 120" hoods, consult factory.	30"	11040	11050	11060	11080	11100	11120
	36"	11042	11052	11062	11082	11102	11122
	48"	11043	11053	11063	11083	11103	11125
<b>2. UniFlow SE VAV Fume Hood:</b> Same as #1 above except equipped with Variable Air Volume VAV restricted bypass feature in place of CAV bypass feature. Ducting must be connected to optional VAV exhaust system controls.	30"	11049	11059	11069	11089	11015	11031
	36"	11046	11056	11066	11086	11016	11032
	48"	11047	11057	11067	11087	11017	11033
<b>3. UniFlow SE Fume Hood with Explosion-Proof Light:</b> Same as # 1 above except equipped with explosion proof vapor tight light fixture. Class I Div II Group A B C & D, Class II Div II Group F & G, 115/230V, 50/60Hz U.L. listed Fixture is installed but must be field wired to local codes.	30"	11041	11051	11061	11081	11101	11121
	36"	11044	11054	11064	11084	11104	11126
	48"	11045	11055	11065	11085	11105	11127
<b>4. UniFlow SE Fume Hood International Configuration:</b> Same as #1 above except equipped to comply to international electrical configuration. 220V/50Hz AC. Optional international electrical configuration, electrical switches, receptacles and exhaust blowers available.	30"	11142	11152	11162	11182	11112	11128
	36"	11143	11153	11163	11183	11123	11129
	48"	11144	11154	11164	11184	11124	11130
<b>5. Horizontal Sliding Doors (4 panels on 2 tracks) - for 96", 120" &amp; 144" hoods only</b>					FMHS-8	FMHS-10	FMHS-12

**Questions / Ready to order**  
Call 1-800-779-4362

**Optional Accessories**

- Plumbing Fixtures (see page 11)
- Fume Hood Fire Extinguisher (see page 14)
- Electrical Services (see page 12)
- Air Flow Monitor (see page 39)

**SE FM (Walk-In) Hood Dimensions**

Width "A"	48"	60"	72"	96"	120"	144"
Width "C"	37"	49"	61"	85"	109"	133"
Diameter "D"	(1) 10"	(1) 10"	(1) 12"	(2) 10"	(2) 12"	(2) 12"

**CAV Fume Hood Face Velocity**   
The recommended face velocity for efficiency & safety is 80-100 FPM. Lower face velocity may compromise user safety. Sash in full open position should be for setup of apparatus & maintenance service only. Design opening is at 1/2 open at 100 FPM (feet per minute), face velocity at full open would be approximately 50 FPM.

**SE FM Floor Mount Fume Hood Sash Management & Design**

Size hood	48"	60"	72"	96"	120"	144"
1/2 open CFM	385	474	592	800	984	1200
Full open CFM	773	938	1162	1613	1968	2401

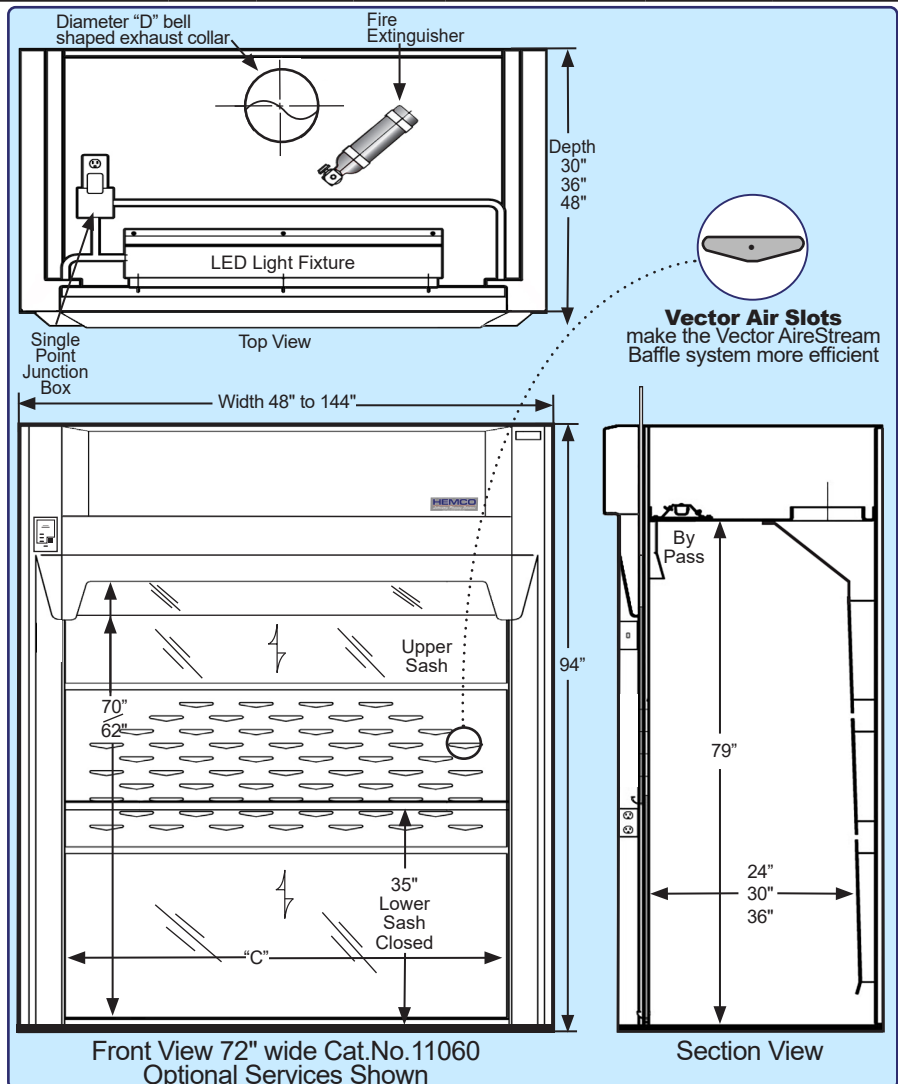

# UniFlow<sup>®</sup> LE FM Distillation Fume Hoods

UniFlow LE FM Floor Mounted (Walk-In) Hoods are ideally suited for synthesis, distillation & other rack type operations where tall apparatus is used or equipment is rolled into the work area. In widths 48", 60", 72", 96", 120" & 144" and depths of 30", 36", & 48". UniFlow Walk-In Hoods are available in standard or special sizes to meet various applications. Modular construction can be shipped disassembled for on-site assembly.



**UniFlow LE FM Hood 5' Cat. No. 12053** shown with vertical rising sash, optional 12" high base table, work surface, & service fixtures.

**UniFlow Superstructure** to be non-metallic FRP composite construction for total chemical resistance, superior durability and long life. Interior fume chamber to be glass-smooth with Vector Baffle System & bell shaped exhaust collar. Modular construction reduces weight for ease of installation. Includes 5 year warranty.

## UniFlow AireStream Vector Baffle

**System** Features Vector Air Flow Slots for low flow and high performance. Maintains uniform air flow thru the baffle system to bell shaped exhaust collar outlet.

**Vapor Proof LED light fixture** polished stainless steel reflectors, and light switch on left column, all factory installed. Energy efficient 15W, 50/60Hz, 100-277VAC. 5 Year warranty. U.L. Listed

**High Efficiency** sash management provides for energy savings.

**User Protection** with sash in lowered position, fumes are kept safely away from the user.

**62" Sash Height** for viewing of fume chamber, loading and unloading equipment for set up. Includes upper and lower sash. 76" Stand Up Height for ease of access and interior depths of 30", 36", and 48" available. With sash in lowered position, fumes are kept safely away from the user.

## 68" Viewing Height Double Vertical Sash

provides ease of access for apparatus set-up in fume chamber. Sashes are perfectly counter balanced, 3/16 tempered safety glass, coated stainless steel cable with stainless steel pulley assembly. Framed in non-metallic PVC framing, track, and aerodynamic sash lifts for ease of movement and air flow efficiency. Horizontal sliding doors are available on 96", 120" and 144" wide models.

## Angled Picture Frame Opening

aerodynamic face opening with air foil provides uniform air flow into the fume chamber, & thru the Vector AireStream Baffle System, to the exhaust collar.

**Energy Efficient** vapor proof LED light fixture with polished stainless steel reflectors, and light switch on left column all factory installed.

**Plumbing Services** fixtures are color coded to specific service. (Optional equipment) (see page 11)

**Electrical Services** can be mounted on right or left side. (Optional equipment) (see page 12)



**Air Flow Monitor** (Optional equipment) continuously monitors face velocity air flow, meets ANSI and OSHA requirements.

**Cat. No. 51403** (see page 39)

## SASH OPTIONS

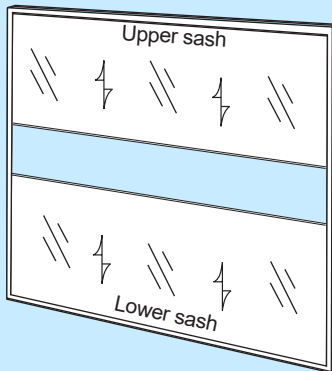

**VERTICAL SASHES** for HEMCO fume hoods, 4', 5', & 6' wide. The sash may be lifted to the completely open position for maximum access thru the fume chamber. Sash stops available.

**HORIZONTAL SASHES** for HEMCO fume hoods, 8', 10', & 12' wide. The maximum sash opening for the horizontal sash is 1/2 that of the vertical sashes. The smaller opening, means less air exhausted resulting in energy savings.



# UniFlow® LE FM Distillation Fume Hoods

UNIFLOW LE FLOOR MOUNT DESCRIPTIONS	Fume Hood Width "A"						
	HOOD DEPTH "B"	WIDTH 48" Cat. No.	WIDTH 60" Cat. No.	WIDTH 72" Cat. No.	WIDTH 96" Cat. No.	WIDTH 120" Cat. No.	WIDTH 144" Cat. No.
<b>1. UniFlow LE Floor Mounted CAV Bypass Fume Hood with Vapor-Proof Light:</b> Super structure to be modular composite chemical resistant FRP non-metal construction. Interior fume chamber to be glass-smooth with bell shaped exhaust collar. Picture frame upper and lower sash opening with counterbalanced upper and lower sashes of clear tempered safety glass with chemical resistant PVC framing, track, and aerodynamic sash lift. Vapor proof LED light fixture and control switch are wired to a single point junction box. 115/60Hz, AC All electrical components are U.L. listed.	30"	12040	12050	12060	12080	12100	12120
	36"	12043	12053	12063	12083	12103	12123
	48"	12044	12054	12064	12084	12104	12124
<b>2. UniFlow LE VAV Fume Hood:</b> Same as #1 above except equipped with Variable Air Volume VAV restricted bypass feature in place of CAV bypass feature. Ducting must be connected to optional VAV exhaust system controls.	30"	12145	12155	12165	12185	12105	12125
	36"	12146	12156	12166	12186	12106	12126
	48"	12147	12157	12167	12187	12107	12127
<b>3. UniFlow LE Fume Hood with Explosion-Proof Light:</b> Same as #1 above except equipped with explosion proof vapor tight light fixture. Class I Div II Group A B C & D, Class II Div II Group F & G, 115/ 230V, 50/60Hz U.L. listed fixture is installed but must be field wired to comply with local codes.	30"	12142	12152	12162	12182	12012	12112
	36"	12143	12153	12163	12183	12013	12113
	48"	12148	12154	12164	12184	12014	12114
<b>4. UniFlow LE Fume Hood International Configuration:</b> Same as #1 above except equipped to comply to international electrical configuration. 220V/50Hz AC. Optional international electrical configuration, electrical switches, receptacles and exhaust blowers available.	30"	12440	12450	12460	12480	12430	12420
	36"	12243	12253	12263	12283	12233	12223
	48"	12244	12254	12264	12284	12234	12224
<b>5. Distillation Base Table</b> Heavy duty welded steel tube table with chemical resistant epoxy powder coat finish, and dished phenolic resin worksurface. Offered in 12" height.	29"	54818	56018	57218	59618	510018	512018
	35"	54838	56038	57238	59638	510038	512038
	47"	54848	56048	57248	59648	510048	512048
<b>6. Horizontal Sliding Doors: for 96", 120" and 144" hoods only</b>					FMHS-8	FMHS-10	FMHS-12
	30"	21415	21515	21615	21815	211015	211215
<b>7. Adaptable Worksurface</b> phenolic resin worksurface is provided to slide into place at desired height. Can then be removed for larger equipment.	36"	21424	21525	21625	21825	211025	211225
	48"	21435	21535	21635	21835	211035	211235

**Questions / Ready to order**  
Call 1-800-779-4362

Optional Accessories	
Plumbing Fixtures (see page 11)	
Fume Hood Fire Extinguisher (see page 14)	
Electrical Services (see page 12)	
Air Flow Monitor (see page 39)	

LE FM Distillation Hood Dimensions						
Width "A"	48"	60"	72"	96"	120"	144"
Width "C"	37"	49"	61"	85"	109"	133"
Diameter "D"	(1) 10"	(1) 10"	(1) 12"	(2) 10"	(2) 12"	(2) 12"

**CAV Fume Hood Face Velocity**  The recommended face velocity for efficiency & safety is 80-100 FPM. Lower face velocity may compromise user safety. Sash in full open position should be for setup of apparatus & maintenance service only. Design opening is at 1/2 open at 100 FPM (feet per minute), face velocity at full open would be approximately 50 FPM.

LE FM Floor Mount Fume Hood Sash Management & Design					
Size hood	48"	60"	72"	96"	144"
1/2 open CFM	385	474	592	800	1200
Full open CFM	773	938	1162	1613	2401

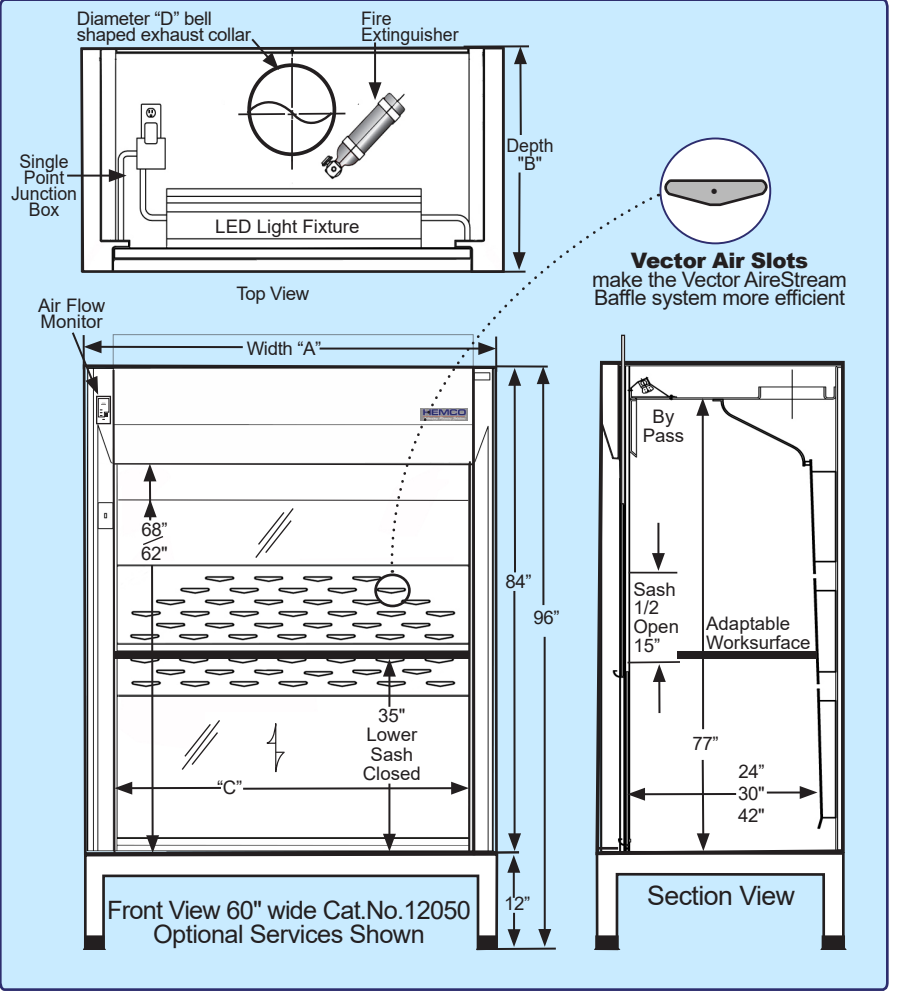

# UniFlow SE Dual Entry Fume Hoods

UniFlow SE Dual Entry Air Bypass Hoods are ideal for demonstration or applications where observation and access is required from both sides of the fume hood. Dual Entry Hoods are available in 48", 60", 72", & 96" widths and in 30", 36" & 48" depths. They can be positioned on an island or in peninsular locations. Dual Entry Hoods can also be located on a common wall of two rooms with accessibility from either room.



## UniFlow SE Dual Entry Fume Hood Cat. No. 12160

shown with optional epoxy resin worksurface, and base cabinets, See pages 10-14 for accessories.

**UniFlow Superstructure** exclusive unitized dual wall construction for superior chemical resistance, strength, and durability. Meets NFPA-45 classification with flame spread of less than 25 per ASTM E-84.

**Access Panel** removable to access ducting connections, plumbing & electrical services from a single point electrical box, 115/60Hz AC operation.

### Full 28" Viewing Height Sash

with 28" sash opening height for ease of access and viewing tall apparatus setup. Sash is 3/16 thick tempered safety glass, with chemical resistant non-metallic PVC framing, track, and aerodynamic sash lift (horizontal sash). Sash handle for efficient air flow and ease of movement. Standard horizontal sash, optional vertical sash, specify sash for each side.

### Angled Picture Frame Opening

the aerodynamic face opening with air foil provides uniform air flow into the fume chamber and thru the bell shaped exhaust collar.



### Air Flow Monitor with Repeater

(Optional equipment) flush mounted air flow Monitor for Dual Entry Fume Hoods only. It features a back lit display which displays the air flow velocity or Air flow status. **Cat No. 51405**

**Plumbing Services** fixtures are color coded to specific service. (Optional equipment) (see page 11)

### Epoxy or Phenolic Worksurfaces

(Optional equipment) (see page 10)

### Fume Hood Base Cabinet

(Optional equipment) (see page 10)

#### HORIZONTAL SASHES

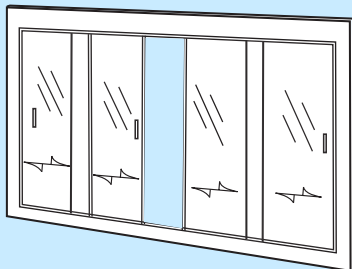

**Horizontal Sashes** The standard sash for dual entry fume hoods. The maximum sash opening for the horizontal sash is 1/2 that of the vertical sashes. The smaller opening, means less air exhausted resulting in energy savings.

#### VERTICAL SASHES

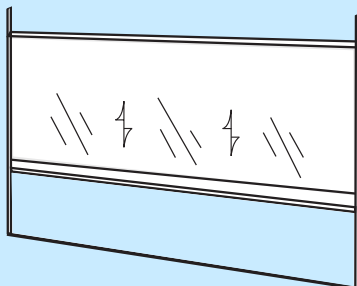

**Vertical Sashes** The optional sash for dual entry fume hoods. The sash may be lifted to the completely open position for maximum access thru the fume chamber. For 4', 5', 6', and 8' hoods only.

#### SIDE VIEW WINDOWS

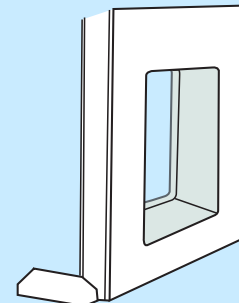

**Optional Side View Windows** Can be installed on right or left sides.

**Side View Window 16" X 20" - Cat. No. 51620**  
**Side View Window 24" X 20" - Cat. No. 52420**

# UniFlow SE Dual Entry Fume Hoods

UNIFLOW SE DUAL ENTRY DESCRIPTIONS		Hood Depth "B"	FUME HOOD WIDTH "A"			
			48" Cat.No.	60" Cat.No.	72" Cat.No.	96" Cat.No.
<b>1. UniFlow SE Dual Entry Bypass CAV Hood 30" Depth:</b> Superstructure to be modular composite chemical resistant FRP non-metal construction. Interior fume chamber to be glass-smooth with bell shaped exhaust collar. Picture frame sash opening in front with (4) horizontal moving sashes constructed of clear tempered safety glass with chemical resistant framing and track. Vapor proof light fixture and control switch are wired to a single point junction box, 115/60Hz, AC All electrical components are U.L. listed.		30"	12140	12150	12160	12180
		36"	12340	12350	12360	12380
		48"	12240	12250	12260	12280
<b>2. Vertical Sash Option:</b> Add suffix to catalog number.			VS-4	VS-5	VS-6	VS-8
<b>3. Epoxy Resin Worksurface:</b> Ideal for high concentrations of solvents, acids and alkalis. Excellent scratch and wear resistance. Dished to contain spillage. 1.25" thick, color: black.		30" deep worksurface	20435	20535	20635	20835
		36" deep worksurface	20455	20555	20655	20855
		48" deep worksurface	20445	20545	20645	20845
<b>4. 30" Base Cabinet Assembly:</b> Consists of cabinet(s) & 8" filler panels of top grade welded furniture steel. Cabinets include two hinged doors. (Side View A)		28" deep - cabinet access from one side only	50430	50530	50630	50830
<b>5. 36" Base Cabinet Assembly:</b> Consists of (2) cabinets & 14" filler panels of top grade welded furniture steel. Cabinets include two hinged doors. (Side View A)		34" deep - cabinet access from one side only	50436	50536	50636	50836
<b>6. 48" Base Cabinet Assembly:</b> Consists of (4) cabinets and 2" filler panels of top grade welded furniture steel. Cabinets include two hinged doors. (Side View B)		46" deep - cabinet access from both sides	50448	50548	50648	50848

## UniFlow SE Dual Entry Hood Dimensions

Width "A"	48"			60"			72"			96"		
Width "C"	38"			50"			62"			86"		
Diameter "D"	10"			10"			12"			(2) 10"		
Depth "B"	30"	36"	48"	30"	36"	48"	30"	36"	48"	30"	36"	48"

Dual entry fume hoods are available with optional worksurface and support cabinets. The 30" & 36" deep models require a standard cabinet with a finished rear panel assembly. 48" deep model requires two cabinets back-to-back plus filler panels allowing cabinet access from both sides.

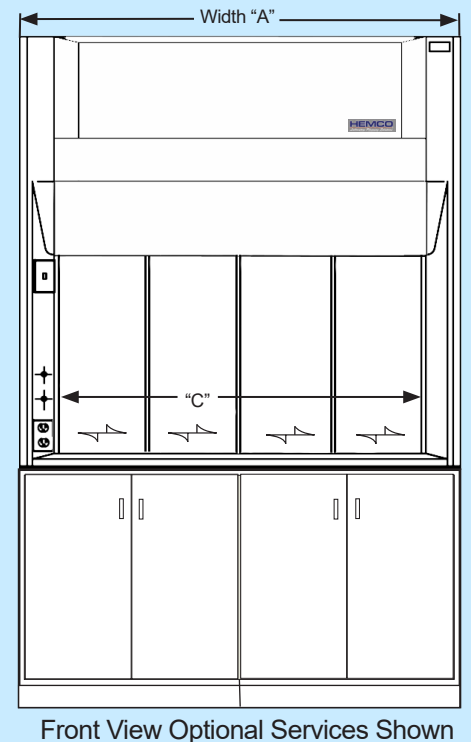
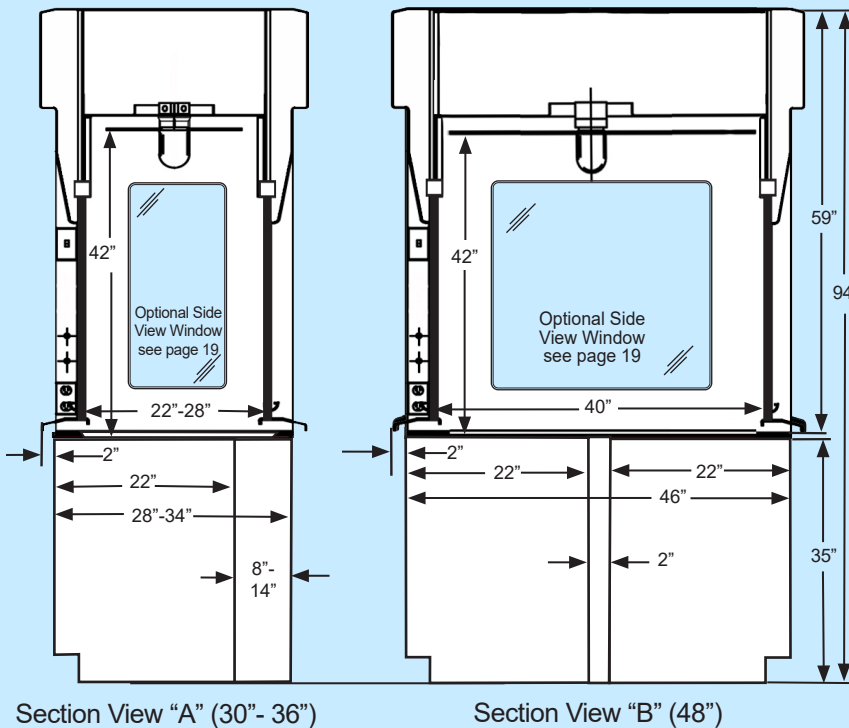
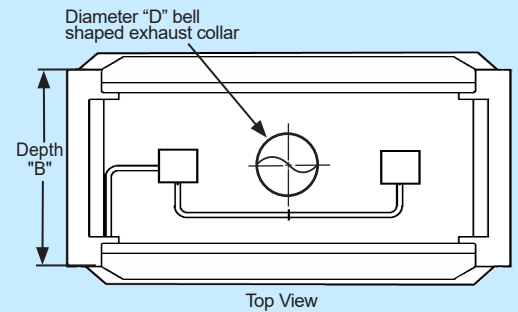



# UniFlow<sup>®</sup> LE Dual Entry Fume Hoods

UniFlow LE Dual Entry Air Bypass Hoods are ideal for demonstrations or applications where observation and access is required from both sides of the fume hood. Dual Entry Hoods are available in 48", 60", 72", & 96" widths and in 30", 36" & 48" depths. They can be positioned on an island or in peninsular locations. Dual Entry Hoods can be also located on a common wall of two rooms with accessibility from either room.



**UniFlow LE Dual Entry Hood Cat. No. 35631** shown with optional epoxy resin worksurface, fixtures, and base cabinets, See pages 10-14 for accessories.

**UniFlow Superstructure** exclusive unitized dual wall construction for superior chemical resistance, strength, and durability. Meets NFPA-45 classification with flame spread of less than 25 per ASTM E-84.

**Access Panel** removable to access ducting connections and electrical services from a single point electrical box, 115/60Hz AC operation.

## Full 28" Viewing Height Sash

with 28" sash opening height for ease of access and viewing tall apparatus setup. Sash is 3/16 thick tempered safety glass, with chemical resistant non-metallic PVC framing, track, and aerodynamic sash lift (horizontal sash). Sash handle for efficient air flow and ease of movement. Standard horizontal sash, optional vertical sash, specify sash for each side.

**Fume Chamber** with coved corners. Surface is white, glass smooth for ease of cleaning and excellent light reflectivity.



## Air Flow Monitor with Repeater

(Optional equipment) flush mounted air flow Monitor for Dual Entry Fume Hoods only. It features a back lit display which displays the air flow velocity or Air flow status. **Cat No. 51405**

**Plumbing Services** fixtures are color coded to specific service. (Optional equipment) (see page 11)

## Fume Hood Fire Extinguisher

(Optional equipment) (see page 14)

## Epoxy or Phenolic Work Surfaces

Optional equipment) (see page 10)

## Fume Hood Base Cabinet

(Optional equipment) (see page 10)

### HORIZONTAL SASHES

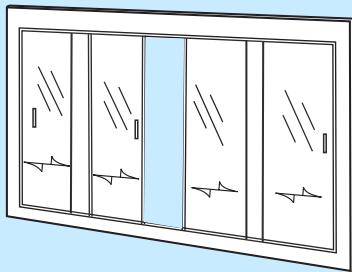

**Horizontal Sashes** The standard sash for dual entry fume hoods. The maximum sash opening for the horizontal sash is 1/2 that of the vertical sashes. The smaller opening, means less air exhausted resulting in energy savings.

### VERTICAL SASHES

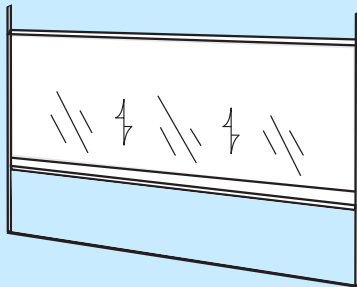

**Vertical Sashes** The optional sash for dual entry fume hoods. The sash may be lifted to the completely open position for maximum access thru the fume chamber. For 4', 5', 6', and 8' hoods only.

### SIDE VIEW WINDOWS

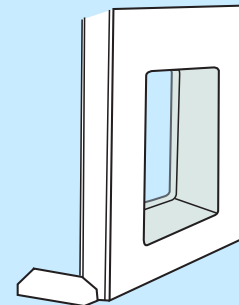

**Optional Side View Windows** Can be installed on right or left sides.  
**Side View Window 16" X 20" - Cat. No. 51620**  
**Side View Window 24" X 20" - Cat. No. 52420**

# UniFlow LE Dual Entry Fume Hoods

UNIFLOW LE DUAL ENTRY DESCRIPTIONS		Hood Depth "B"	FUME HOOD WIDTH "A"			
			48" Cat.No.	60" Cat.No.	72" Cat.No.	96" Cat.No.
<b>1. LE Dual Entry Bypass CAV Hood:</b> Superstructure to be modular composite chemical resistant FRP non-metal construction. Interior fume chamber to be glass-smooth with bell shaped exhaust collar. Picture frame sash opening in front with (4) horizontal moving sashes constructed of clear tempered safety glass with chemical resistant framing and track. Vapor proof light fixture and control switch are wired to a single point junction box. 115/60Hz, AC All electrical components are U.L. listed. Optional electrical services see page 12.		30"	35431	35531	35631	35831
		36"	35441	35541	35641	35841
		48"	35451	35551	35651	35851
<b>2. Vertical Sash Option:</b> Add suffix to catalog number. Includes sash stops at 1/2 open position.			VS-4	VS-5	VS-6	VS-8
<b>3. Epoxy Resin Worksurface:</b> ideal for high concentrations of solvents, acids and alkalis. Excellent scratch and wear resistance. Dished to contain spillage. 1.25" thick, color: black.		30" deep worksurface	20435	20535	20635	20835
		36" deep worksurface	20455	20555	20655	20855
		48" deep worksurface	20445	20545	20645	20845
<b>4. 30" Base Cabinet Assembly:</b> Consists of cabinet(s) & 8" filler panels of top grade welded furniture steel. Cabinets include two hinged doors. (Side View A)		28" deep - cabinet access from one side only	50430	50530	50630	50830
<b>5. 36" Base Cabinet Assembly:</b> Consists of (2) cabinets & 14" filler panels of top grade welded furniture steel. Cabinets include two hinged doors. (Side View A)		34" deep - cabinet access from one side only	50436	50536	50636	50836
<b>6. 48" Base Cabinet Assembly:</b> Consists of (4) cabinets and 2" filler panels of top grade welded furniture steel. Cabinets include two hinged doors. (Side View B)		46" deep - cabinet access from both sides	50448	50548	50648	50848

## UniFlow LE Dual Entry Hood Dimensions

Width "A"	48"	60"	72"	96"								
Width "C"	37"	49"	61"	85"								
Diameter "D"	10"	10"	12"	(2) 10"								
Depth "B"	30"	36"	48"	30"	36"	48"	30"	36"	48"	30"	36"	48"

Dual entry fume hoods are available with optional worksurface and support cabinets. The 30" deep model requires a standard with a finished rear panel assembly. 48" deep model requires two cabinets back-to-back plus filler panels, allowing cabinet access from both sides.

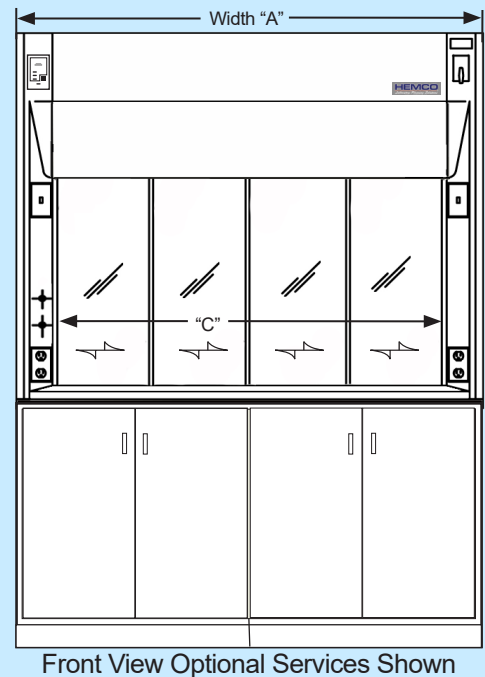
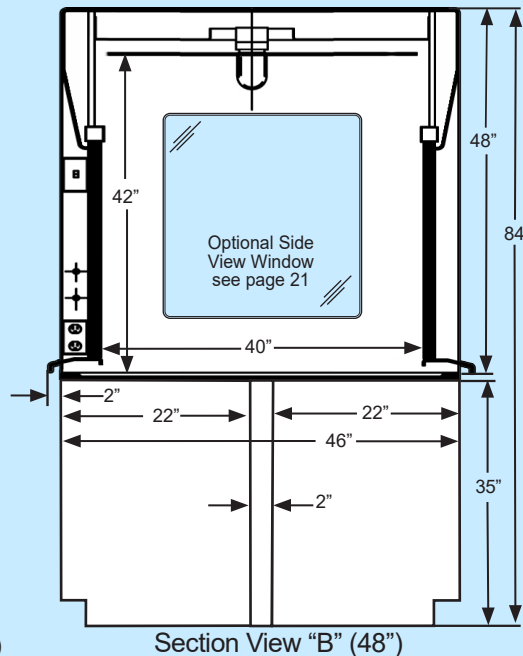
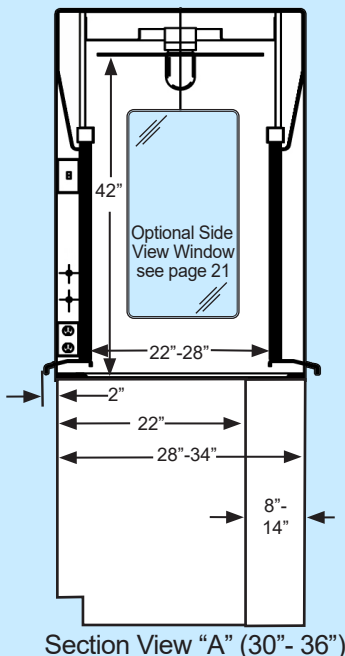
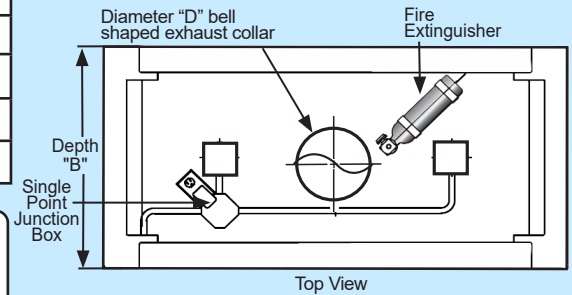

# UniFlow Auxiliary Air Fume Hoods

Zero room air requirements. The Fume hood exhaust is equal to the auxiliary supply air, thereby zero room air is required. With the sash in the 1/2 open position and face velocity of 100 feet per minute, the CFM required equals the air supply. The hood exhaust air plus auxiliary air make up for room supply deficiencies. Since expensive tempered room air is not required, Auxiliary Air Fume Hoods provide energy savings.



**UniFlow Auxiliary Air Hood Cat. No. 21521** shown with optional epoxy resin work surface, fixtures, and base cabinets, See pages 10-14 for accessories.

**UniFlow Superstructure** exclusive unitized dual wall construction for superior chemical resistance, strength, and durability. One-piece interior fume chamber to be glass-smooth with VaraFlow baffle system & bell shaped exhaust collar. Meets NFPA-45 classification with flame spread of less than 25 per ASTM E-84.

**Access Panel** removable to access ducting connections and electrical services from a single point electrical box, 115/60Hz AC operation.

**Vapor Proof LED light fixture** polished stainless steel reflectors, and light switch on left column, all factory installed. Energy efficient 15W, 50/60Hz, 115V-230VAC. 5 Year warranty. U.L. Listed

**28" Vertical Sash Height** provides ease of access for apparatus set-up in fume chamber. 24" interior reach in depth, and 44" interior working height. Sash is perfectly counter balanced, 3/16 tempered safety glass, coated stainless steel cable with stainless steel pulley assembly. Framed in nonmetallic PVC framing, track, and aerodynamic sash lift for ease of movement and air flow efficiency.

**Plumbing Services** fixtures are color coded to specific service. (Optional equipment) (see page 11)

**Epoxy or Work Surfaces** (Optional equipment) (see page 10)

**Fume Hood Base Cabinet** (Optional equipment) (see page 10)



**Air Flow Monitor** (Optional equipment) continuously monitors face velocity air flow, meets ANSI and OSHA requirements.

**Cat. No. 51403** (see page 39)

## UniFlow Auxiliary Air Fume Hoods

- Auxiliary-Air fume hoods are equipped with auxiliary air plenum to induce added air flow to induce added air flow to face opening of hood.
- Supply air ducting and remote blower are required.
- Example: A 60" Hood with the sash 1/2 open, and an exhaust of 474 CFM combined with a 474 CFM supply of ambient air. The amount of make up room air required would be zero.

## Auxiliary Air Flow Diagram

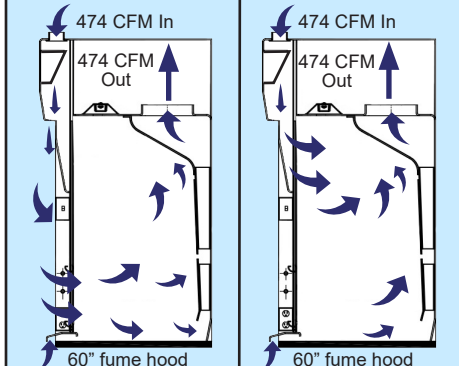

Air flow (sash open) auxiliary make-up, air enters supply plenum and is distributed down the exterior face in through sash opening. Near zero room air.

Air flow (sash closed) auxiliary make-up, air diverts from the supply plenum through the air-bypass opening into the fume chamber. Near zero room air.

## UniFlow Auxiliary Air Fume Hood

### Zero Room Air

- For a 60" UniFlow Auxiliary Air fume hood Cat. No. 21521

1. Sash opening design set at 1/2 open, and 100 FPM face velocity. The exhaust CFM is 474 CFM out.
2. The Auxiliary Air supply blower is set at 474 CFM input.
3. This balances out the theoretical room air requirement to 0 CFM.

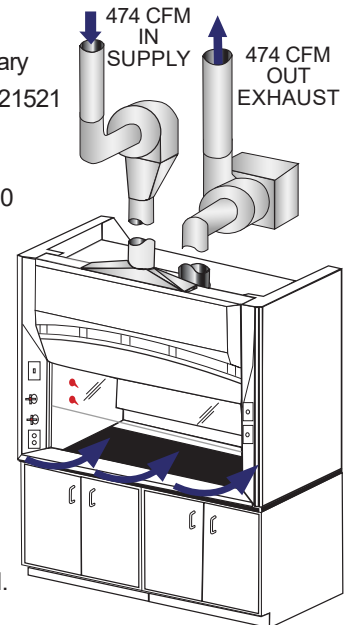



# UniFlow Auxiliary Air Fume Hoods

UNIFLOW AUXILIARY AIR DESCRIPTIONS		Hood Depth "B"	FUME HOOD WIDTH "A"		
			48" Cat.No.	60" Cat.No.	72" Cat.No.
<b>1. UniFlow Auxiliary Air CAV Bypass Fume Hood with Vapor-Proof Light:</b> Superstructure to be unitized composite FRP fire resistant non-metallic construction. Integral fume chamber to be seamless glass-smooth with all covered corners with adjustable VaraFlow baffle system and bell shaped exhaust collar. Picture frame sash opening with counterbalanced clear tempered safety glass sash with chemical resistant PVC framing, track, and aerodynamic sash lift. Built-in auxiliary air supply plenum to reduce volume of conditioned air from room. Vapor-proof LED light fixture and control switch pre-wired to single point junction box, 115/60Hz AC, All electrical components U.L. listed. Requires a remote exhaust blower, based on 50% supply air makeup.		30"	21421	21521	21621
<b>2. UniFlow Auxiliary Air By Pass Fume Hood with Explosion-Proof Light:</b> Same as #1 above except equipped with explosion-proof vapor-proof light fixture Class I, Div II Groups A B C & D, Class II Div II Groups F & G electrical fixture installed but not wired, must be wired to comply with local codes. 115/230V, 50/60Hz AC. For other explosion-proof electrical options see page 12, auxiliary supply blower see below. All electrical components UL listed.		30"	21423	21523	21623
<b>AUXILIARY AIR SUPPLY BLOWERS</b>					
<b>3. Supply blower, belt drive, coated steel with:</b> V-belt drive and adjustable pulleys permit field balancing. Weather housing and drain is furnished. Motor has thermal overload protection Specify 115V 1 ph, 230V 1 ph, 230/460V 3 ph. Blowers based on 50% supply makeup.	For 48" 1/4 HP 385 CFM @ 1/2" S.P. Loss		51901		
	For 60" 1/4 HP 474 CFM @ 1/2" S.P. Loss			51902	
	For 72" 1/4 HP 542 CFM @ 1/2" S.P. Loss				51903

**Questions / Ready to order  
Call 1-800-779-4362**

Width "A"	48"	60"	72"
Width "C"	38"	50"	62"
Diameter "D"	10"	10"	12"
Dimension "E"	3" X 12"	3" X 18"	3" X 24"

**CAV Fume Hood Face Velocity**

The recommended face velocity for efficiency & safety is 80-100 FPM. Lower face velocity may compromise user safety. Sash in full open position should be for setup of apparatus & maintenance service only. Design opening is at 1/2 open at 100 FPM (feet per minute), face velocity at full open would be approximately 50 FPM.

Size Hood	48"	60"	72"
1/2 Open CFM	385	474	592
Full Open CFM	773	938	1162

**Sash Stop** located at 1/2 open position to reduce air flow volume 50%, provides best possible user protection and safety. **Cat. No. 51651**

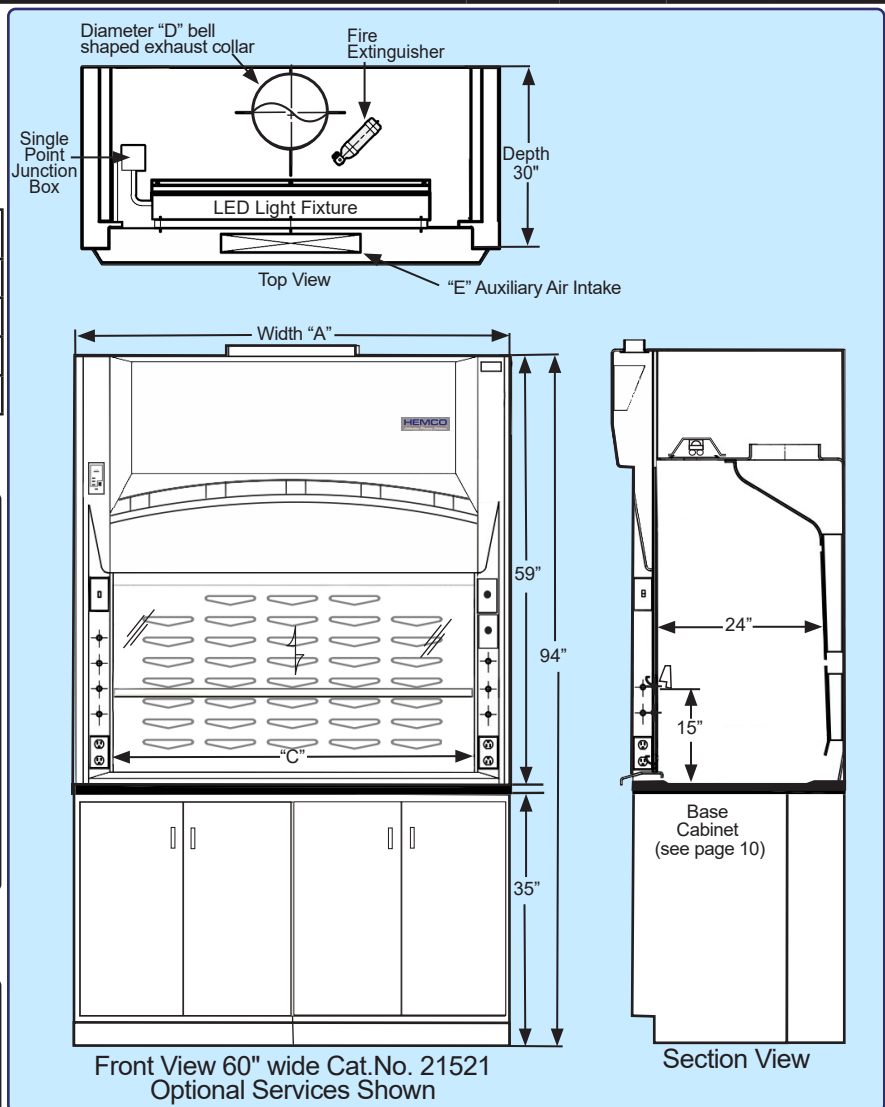

# UniFlow<sup>®</sup> Perchloric Acid Fume Hoods

UniFlow Perchloric Acid Fume Hoods feature either a type 316 stainless steel or PVC one-piece fume chamber with integral worksurface and are engineered for the safe handling of perchloric acids in laboratory procedures. Perchloric Acid Hoods are offered in sizes 48", 60", & 72" widths and include a dedicated wash down and exhaust system. It is recommended to thoroughly wash down fume chamber and exhaust system after each use. Note: Perchloric Acid Hoods are for perchloric acid use only.



**UniFlow Perchloric Acid Hood Cat. No. 12501**  
shown with optional base cabinets and fixtures,  
See pages 10-14 for accessories.

## Optional Accessories

**Plumbing Fixtures** are color coded to specific service.  
(see page 11)

**Electrical Services** (see page 12)

**Acid Cabinet** (see page 10)

**Fume Hood Base Cabinet** (see page 10)

**Apparatus Rack** (see page 14)

**UniFlow Superstructure** constructed of either PVC or 316 stainless steel features exclusive unitized dual wall construction for superior chemical resistance, strength, and durability. Rear drain trough is integral to superstructure. Dedicated wash down with integral piping spray nozzles & remote control on right column. One-piece interior fume chamber type 316 stainless steel fume or PVC fume chamber and baffle. Meets NFPA-45 classification with flame spread of less than 25 per ASTM E-84.

**PVC or Stainless Steel Worksurfaces**  
integral PVC or 316 stainless steel worksurface.

**Access Panel** removable to access ducting connections, plumbing & electrical services from a single point electrical box, 115/230V, 50/60Hz AC operation. Energy efficient explosion proof light fixture with light switch on left column, all factory installed.

**28" Vertical Sash Height** provides ease of access for apparatus set-up in fume chamber. 24" or 30" interior reach in depth, and 44" interior working height. Sash is perfectly counter balanced, 3/16 tempered safety glass, coated stainless steel cable with stainless steel pulley assembly. Framed in nonmetallic PVC framing, track, and aerodynamic sash lift for ease of movement and air flow efficiency.



**Air Flow Monitor** (Optional equipment) continuously monitors face velocity air flow, meets ANSI and OSHA requirements.

**Cat. No. 51403** (see page 39)

**OPTIONAL ACCESSORIES**  
Refer to HEMCO's PLAN-A-HOOD on page 9 to assist in the planning of UNIFLOW fume hoods.

**Ducting & Wash Down Systems**  
(by others)

**Perchloric Acid Exhaust Blowers**  
(see page 41)

**Air Flow Monitors**  
(see page 39)

**Plumbing and Electrical Services**  
Factory installed according to your exact specifications  
(see page 11)

**Base Cabinets and Worksurfaces**  
(see page 10)

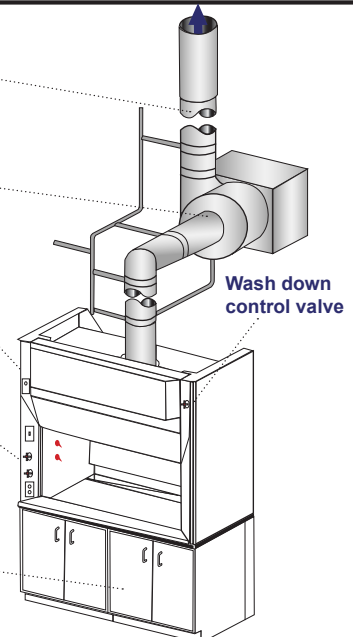

# UniFlow® Perchloric Acid Fume Hoods

## UNIFLOW PERCHLORIC ACID FUME HOODS DESCRIPTIONS

Hood Depth "B"	FUME HOOD WIDTH "A"		
	48" Cat.No.	60" Cat.No.	72" Cat.No.
30"	12401	12501	12601
36"	12411	12511	12611
30"	12421	12521	12621
36"	12431	12531	12631
<b>PERCHLORIC ACID EXHAUST BLOWERS</b>			
3. Blowers are constructed of fluoropolymer coated steel, belt driven, includes explosion proof motor, non-sparking wheel, spray wash nozzle and drain in the blower housing. The specifications to the right are based on 120 FPM face velocity.	(For 48" hoods) 475 CFM @ 1/2 open (For 48" hoods) 950 CFM @ full open	52395 51395	
	(For 60" hoods) 625 CFM @ 1/2 open (For 60" hoods) 1250 CFM @ full open		52396 51396
	(For 72" hoods) 765 CFM @ 1/2 open (For 72" hoods) 1525 CFM @ full open		52397 51397
4. Optional stainless steel stack outlet with wash down nozzles:		51398	51398 51399

**Questions / Ready to order**  
**Call 1-800-779-4362**

UniFlow Perchloric Acid Hood Dimensions			
Width "A"	48"	60"	72"
Width "C"	38"	50"	61"
Diameter "D"	10"	10"	12"

**Fume Hood Face Velocity** 

The recommended face velocity for efficiency & safety is 80-100 FPM. Lower face velocity may compromise user safety. Sash in full open position should be for setup of apparatus & maintenance service only. Design opening is at 1/2 open at 100 FPM (feet per minute), face velocity at full open would be approximately 50 FPM.

Sash Management & Design			
Size Hood	48"	60"	72"
1/2 Open CFM	475	625	765
Full Open CFM	950	1250	1525

**Sash Stop** located at 1/2 open position to reduce air flow volume 50%, provides best possible user protection and safety.  **Cat. No. 51651**

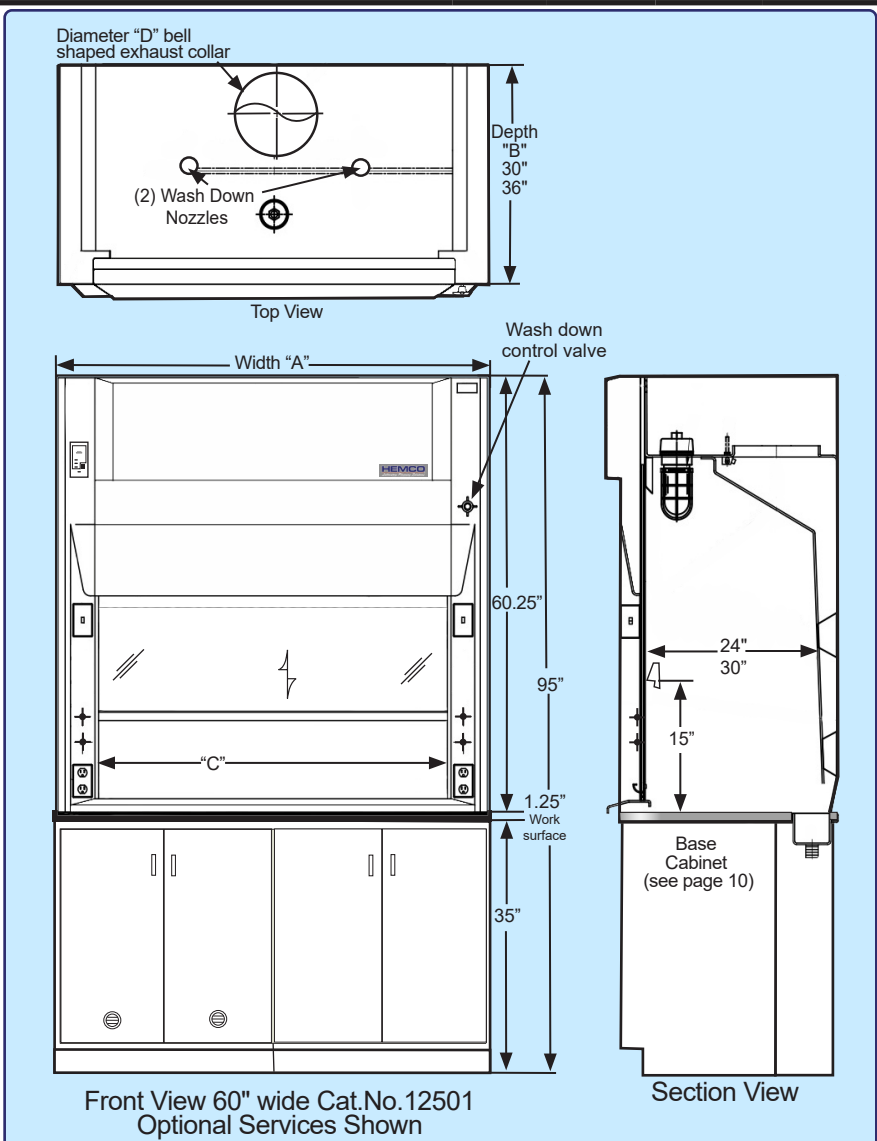



# UniFlow<sup>®</sup> HDPE Acid Digestion Fume Hoods

UniFlow HDPE Acid Digestion Fume Hoods feature a one-piece fume chamber with integral reinforced work surface, and baffles constructed of High Density Polyethylene. Digestion hoods come in 48", 60" & 72" widths & feature a dedicated wash down & exhaust system.



**UniFlow HDPE Acid Digestion Hood**  
Cat. No. 23511 shown with optional base cabinet and fixtures. See pages 10-14 for accessories.

**UniFlow Superstructure** constructed of HDPE exclusive unitized dual wall construction for superior chemical resistance, strength, and durability. Vent outlet is integral to superstructure and is available in HDPE lined hoods.

**Fume Chamber** and baffle are constructed with HDPE liner with 24" or 30" interior depth. The one-piece liner is engineered to resist reactions from corrosive chemicals that don't require high temperatures.

**HDPE Worksurface** is welded integral to the fume hood superstructure and dished to contain spillage and includes welded in rear drain trough. If a sink is required HDPE would allow the sink to be welded in.

**Access Panel** removable to access ducting connections and electrical services from a single point electrical box, 115/60Hz AC operation.

**Vapor Proof LED light fixture** polished stainless steel reflectors, and light switch on left column, all factory installed. Energy efficient 15W, 50/60Hz, LED light 115V 230 VAC. 5 Year warranty. U.L. Listed

**28" Vertical Sash Height** provides ease of access for apparatus set-up in fume chamber. 24" or 30" interior reach in depth, and 44" interior working height. Sash is perfectly counter balanced, 3/16 tempered safety glass, coated stainless steel cable with stainless steel pulley assembly. Framed in nonmetallic PVC framing, track, and aerodynamic sash lift for ease of movement and air flow efficiency.

**Wash Down System** hood is equipped with spray nozzles, piping, valve and rear drain trough for rinsing wash down after usage.



**Air Flow Monitor** (Optional equipment) continuously monitors face velocity air flow, meets ANSI and OSHA requirements.

Cat. No. 51403 (see page 39)

## SASH MANAGEMENT 1-2-3

**Cut Energy Costs up to 50%, by reducing the size of the blower & ductwork required, while lowering installation costs. (see page 38)**

1. Important: by incorporating Sash Management 1-2-3, you are saving 50% on overall energy costs, and providing the best possible user protection & safety.
2. Recommended that hoods be used with sash 1/2 open with face velocity of 80-100 FPM. Sash stop located at 1/2 open position. With upper sash raised to the 1/2 open position the supply air CFM & static pressure are as noted. (see page 4)
3. Sash in full open position should be for setup of apparatus & maintenance service only. If design opening is at 1/2 open at 100 FPM, face velocity at full open would be approximately 50 FPM. The recommended face velocity for efficiency & safety is 80-100 FPM. Lower face velocity may compromise user safety.
4. When hood is not in use, keep sash in closed position.
5. Sash stops are standard on U.L. Classified Fume Hoods. UniFlow SE, LE and CE AirStream fume hoods
6. The Sash Stop is designed for user protection and CFM reduction. Allows sash to open to a maximum of half open, providing up to 50% energy savings.
7. Sash at full open is primarily designed for set-up of equipment and maintenance. Fume hood users should wear personal safety protection equipment, consult Lab Safety Officer.
8. HEMCO recommends 10-12 room air changes per hour for the health & safety of personnel. Example 10' X 20' room 10' high receiving 10 room air changes per hour requires 350 CFM air flow through the lab.
9. At an average utility rate of \$7.00 per CFM, a typical annual savings on a 4' fume hood would be \$2705.00 and on a 6' fume hood \$4067.00, by using Sash Management 1-2-3., Sash Stop at 50% open.

# UniFlow<sup>®</sup> HDPE Acid Digestion Fume Hoods

UNIFLOW HDPE ACID DIGESTION DESCRIPTIONS		Hood Depth "B"	FUME HOOD WIDTH "A"		
			48" Cat.No.	60" Cat.No.	72" Cat.No.
<b>1. Uniflow HDPE Acid Digestion Laboratory Fume Hood:</b> Seamless HDPE fume chamber with integral worksurface and drainage trough, all covered corners with baffle and exhaust collar. Hood has built-in wash down system with spray nozzles and piping to front mounted control valve. Picture frame sash opening with counterbalanced clear polycarbonate sash with chemical resistant PVC framing and track and aerodynamic sash lift. Vapor proof LED light fixture and control switch are wired to a single point junction box, 115/60Hz, AC All electrical components are U.L. listed.	30"	23411	23511	23611	
	36"	23421	23521	23621	
	30"	23431	23531	23631	
<b>2. Uniflow HDPE Acid Digestion Laboratory Fume Hood:</b> Same as #1 above, except without trough and wash down.	36"	23441	23541	23641	
	<b>3. Polypro Exhaust Blower:</b> Belt driven, include TEFC motors and feature a spray wash nozzle and drain in the blower housing. The specifications to the right are based on 100 FPM face velocity.		(For 48" hoods) 1/2 HP Blower - 800 CFM @ 1" SP	51495	
		(For 60" hoods) 1/2 HP Blower - 1000 CFM @ 1" SP		51496	
		(For 72" hoods) 3/4 HP Blower - 1200 CFM @ 1" SP		51497	

**Questions / Ready to order**  
Call 1-800-779-4362

Width "A"	48"	60"	72"
Width "C"	38"	50"	62"
Diameter "D"	10"	10"	12"

- Optional Accessories**
- Plumbing Fixtures** are color coded to specific service. (see page 11)
  - Electrical Services** (see page 12)
  - Air Flow Monitor** (see page 39)
  - Acid Cabinet** (see page 10)
  - Fume Hood Base Cabinet** (see page 10)

**Fume Hood Face Velocity**  The recommended face velocity for efficiency & safety is 80-100 FPM. Lower face velocity may compromise user safety. Sash in full open position should be for setup of apparatus & maintenance service only. Design opening is at 1/2 open at 100 FPM (feet per minute), face velocity at full open would be approximately 50 FPM.

Size Hood	48"	60"	72"
1/2 Open CFM	385	474	592
Full Open CFM	773	938	1162

**Sash Stop** located at 1/2 open position to reduce air flow volume 50%, provides best possible user protection and safety.  **Cat. No. 51651**

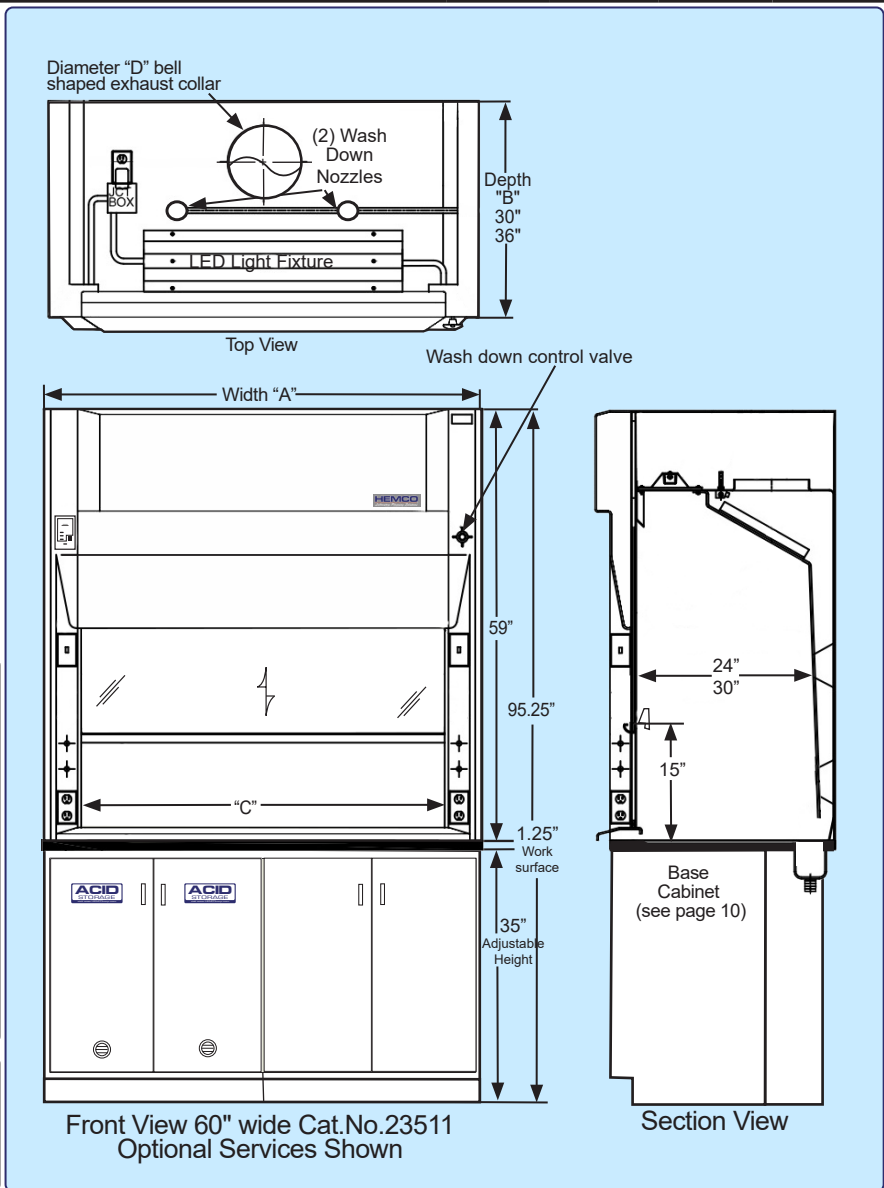

# UniFlow Polypro Trace Metals Fume Hoods

UniFlow Polypro Trace Metals Fume Hoods are designed for applications where no metal can be present. These hoods feature a totally non-metallic construction and are available in sizes of 48", 60", and 72" widths and 30" or 36" depths.



**UniFlow Polypro Trace Metals Fume Hood**  
Cat. No. 25041 shown with optional polypro cabinet and fixtures. See pages 10-14 for accessories.

**UniFlow Superstructure** features a welded one-piece polypropylene fume chamber with integral worksurface with baffle and exhaust collar, creating a chemical resistant, dual wall construction. Meets NFPA 45 requirements for flame spread.

**Fume Chamber** Polypro surface is chemical resistant white, glass smooth for ease of cleaning & light reflectivity.

**VaraFlow Baffle System** constructed of same polypropylene, maintains uniform air flow thru the fume chamber to exhaust collar outlet.

**Energy Efficient** vapor proof non-metallic light fixture with light switch on left column, with PVC conduit and junction box.

**Access Panel** removable to access ducting connections and electrical services from a single point PVC electrical box, 115/60Hz AC operation.

**28" Viewing Height** interior fume chamber with 24" or 30" interior reach in depth. 44" interior working height, allowing for tall apparatus and distillation grid.

**Angled Picture Frame Opening** the aerodynamic face opening with air foil provides uniform air flow into the fume chamber and thru the VaraFlow baffle system to the exhaust collar.



**Air Flow Monitor** (Optional equipment) continuously monitors face velocity air flow, meets ANSI and OSHA requirements.

**Cat. No. 51403** (see page 39)

## Polypro Base Cabinet Features:

- Polypro Base Cabinets constructed of chemical resistant polypropylene in sizes 30", 36" & 48" wide, 35" high & 22" deep.
- Polypro chemical resistant cabinets feature welded seams and overlapping doors.
- Cabinets equipped with a lower lip to contain chemical spills.



## Polypro Cabinet Descriptions

Cabinet Width	30"	36"	48"
Cat. No.	83011	80311	80411
Side Rear Filler Panel		(13")	84113
Polypro Cabinet Vent Kit			Cat. No 81000

## SASH OPTIONS

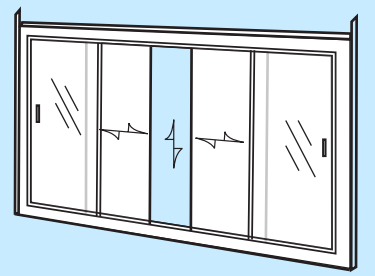
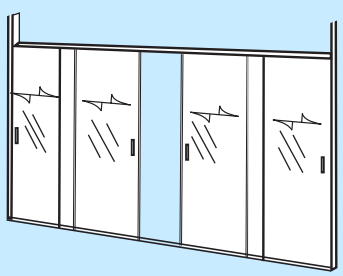

**Horizontal Sashes**  
Max opening is 50%, (4) panels on (2) tracks, conveniently lift out for equipment set-up or cleaning. For 50% reduction of air supply.

**Combination Horizontal / Vertical Sash** Offers the advantages of both sash types. Horizontal sash offer energy savings while vertical option allows full access to the fume chamber.



# UniFlow Polypro Trace Metals Fume Hoods

UNIFLOW POLYPRO TRACE METALS HOODS DESCRIPTIONS		Hood Depth "B"	FUME HOOD WIDTH "A"		
			48" Cat.No.	60" Cat.No.	72" Cat.No.
<b>1. Uniflow Polypro Trace Metal Laboratory Fume Hood:</b> Welded one-piece polypro fume chamber with integral worksurface, baffle and exhaust collar. Picture frame sash opening with horizontal sliding with chemical resistant PVC framing and track and aerodynamic sash lift. Vapor-proof light fixture and switch pre-wired to single point PVC junction box, 115/60Hz AC, All electrical components U.L. listed. Optional electrical services and LED lighting see page 12.	30"	25041	25051	25061	
	36"	25141	25151	25161	
	<b>2. Polypro Trace Metals Exhaust Blower:</b> High efficiency impellers produce low power consumption, reduced operating costs and quiet operation. 20 forward curved blades in fire retardant polypropylene. Non-static & oil resistant V-belt, cast iron pulleys, adjustable pulleys available, adjustment for tensioning & belt replacement. Chemical resistant for hostile or hazardous environments. 115V single phase or three phase. (see page 42)		(For 48" hoods) 1/2 HP Blower 400 CFM @ 1" SP  (For 60" hoods) 1/2 HP Blower 500 CFM @ 1" SP  (For 72" hoods) 3/4 HP Blower 600 CFM @ 1" SP	51495	51496

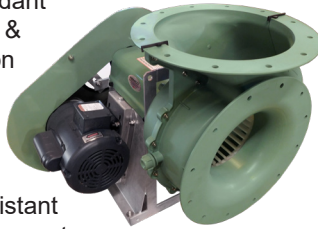

Width "A"	48"	60"	72"
Width "C"	38"	50"	61"
Diameter "D"	10"	10"	12"

- Optional Accessories**
- Plumbing Fixtures** are color coded to specific service. (see page 11)
  - Electrical Services** (see page 12)
  - Air Flow Monitor** (see page 39)
  - Fume Hood Acid Base Cabinet** are acid resistant, & feature a composite liner. (see page 10)
  - Apparatus Rack** (see page 14)

**Fume Hood Face Velocity**   
 The recommended face velocity for efficiency & safety is 80-100 FPM. Lower face velocity may compromise user safety. Sash in full open position should be for setup of apparatus & maintenance service only. Design opening is at 1/2 open at 100 FPM (feet per minute), face velocity at full open would be approximately 50 FPM.

Size Hood	48"	60"	72"
1/2 Open CFM	400	500	600

**Sash Stop** located at 1/2 open position to reduce air flow volume 50%, provides best possible user protection and safety.  **Cat. No. 51651**

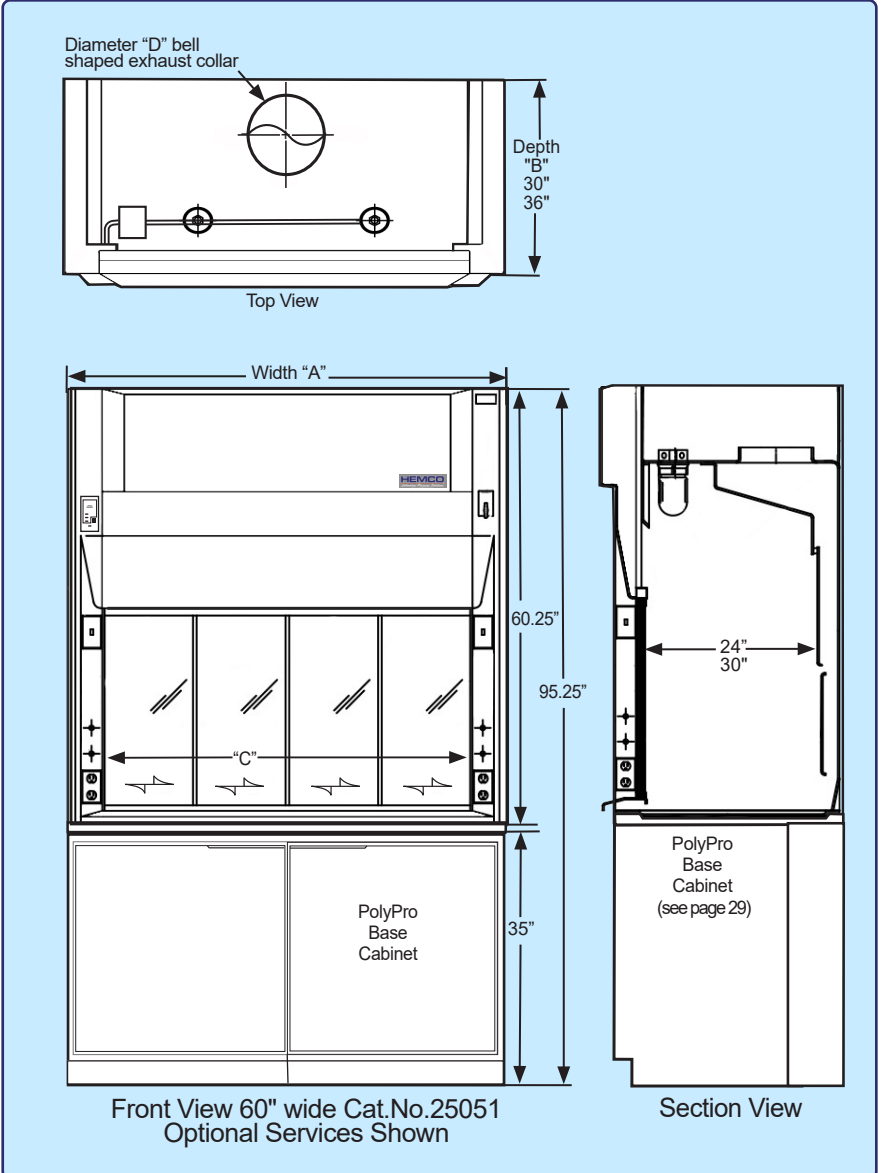

# UniFlow® Radioisotope Fume Hoods

UniFlow Radioisotope Fume Hoods are available in 48", 60", & 72" widths. Interior fume chamber is constructed of welded type 304 stainless steel to prevent absorption of radioactive and corrosive materials. Stainless steel baffle is removable for ease of cleaning. Worksurface is welded integral to the fume chamber and reinforced to support heavy isotope shielding materials.



**UniFlow Radioisotope Fume Hood Cat. No. 14601** shown with optional base cabinet and fixtures. See pages 10-14 for accessories.

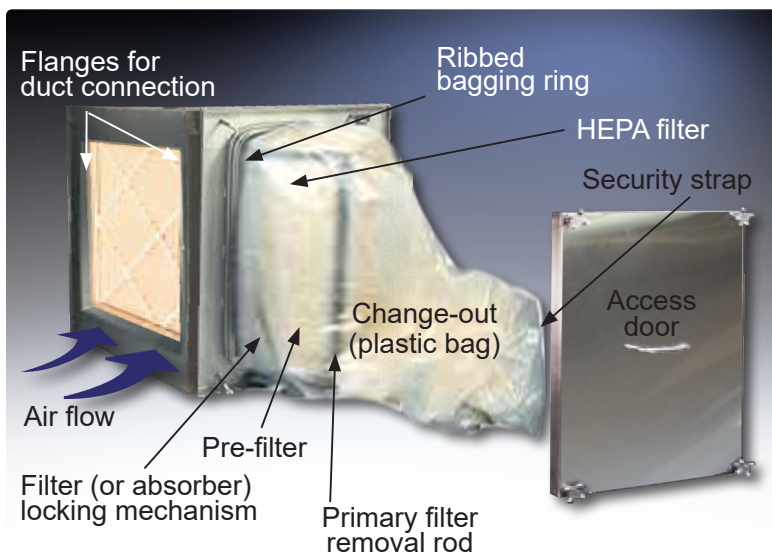

**UniFlow Superstructure** to be non-metallic FRP composite construction for total chemical resistance, superior durability and long life. Interior fume chamber to be glass-smooth with VaraFlow baffle system & bell shaped exhaust collar. Meets NFPA 45 requirements for flame spread.

**Air Foil & Worksurface** are constructed of type 304 stainless steel.

**Fume Chamber** surface is type 304 stainless steel, # 4 satin finish.

**VaraFlow Baffle System** maintains uniform air flow thru the fume chamber to exhaust collar outlet.

**Access Panel** removable to access ducting connections and electrical services from a single point electrical box, 115/60Hz AC operation.

**Vapor Proof LED light fixture** polished stainless steel reflectors, and light switch on left column, all factory installed. Energy efficient 15W, 50/60Hz, 115/230VAC. 5 Year warranty. U.L. Listed

**28" Vertical Sash Height** provides ease of access for apparatus set-up in fume chamber. 24" interior reach in depth, and 44" interior working height. Sash is perfectly counter balanced, 3/16 tempered safety glass, coated stainless steel cable with stainless steel pulley assembly. Framed in Stainless steel framing, track, and aerodynamic sash lift for ease of movement and air flow efficiency.

**Angled Picture Frame Opening** the aerodynamic face opening with stainless steel air foil provides uniform air flow into the fume chamber.

**Plumbing Services** fixtures are color coded to specific service. (Optional equipment) (see page 11)

## Optional Accessories

**Ducting and Ventilation Systems** Stainless steel ducting is recommended. (by others)

**Radioisotope Exhaust Blowers and Filters**

**Air Flow Monitor and Sash Stop** (see page 39)

**Plumbing and Electrical Services** Factory installed according to your exact specifications (see page 11)

**Integral Stainless Steel Dished Worksurface** reinforced to support isotope containers.

**Base Cabinets and Worksurfaces** (see page 10)

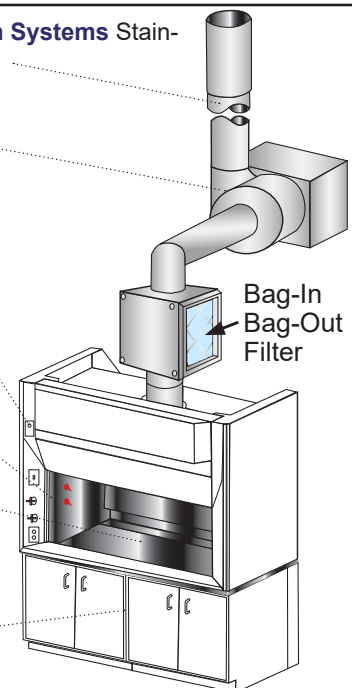

# UniFlow® Radioisotope Fume Hoods

UNIFLOW RADIOISOTOPE FUME HOOD DESCRIPTIONS		Hood Depth "B"	FUME HOOD WIDTH "A"		
			48" Cat.No.	60" Cat.No.	72" Cat.No.
<b>1. UniFlow Radioisotope Fume Hood with Stainless Steel Interior Liner.</b> Seamless type 304 stainless steel fume chamber with integral worksurface all covered corners with baffle and exhaust collar. Picture frame sash opening with counterbalanced clear tempered safety glass sash with chemical resistant stainless steel framing, track, and aerodynamic sash lift. Vapor proof LED light fixture and control switch are wired to a single point junction box, 115/60Hz, 230V 50Hz, VAC All electrical components are U.L. listed. Optional electrical services see page 12.		30"	14401	14501	14601
<b>RADIOISOTOPE EXHAUST BLOWERS &amp; FILTER SYSTEMS</b>					
<b>2. Radioisotope Exhaust Blowers</b> V-belt drive stainless steel blower with adjustable shelves, thermal overload protection, and weather cover. The specifications at right are based on 100 FPM face velocity.	(For 48"hoods) 1/2 HP Blower - 800 CFM @ 1" SP		51715-1		
	(For 60"hoods) 1/2 HP Blower - 938 CFM @ 1" SP			51721-1	
	(For 72"hoods) 1/2 HP Blower -1175 CFM @ 1" SP				51724-1
<b>3. HEPA Filter Bag-In/Bag-Out Filter</b> is contained within a type 304 stainless steel housing with bag-in/bag-out attachment and prefilter. HEPA is 99.99% efficient and the prefilter is 30% efficient. Filter is rated at 1000 CFM. One filter required for 48" and 60" hoods; 2 filters required for 72" hoods.			51189	51189	51189
<b>4. Carbon Filter Bag-In/Bag-Out Filter</b> is contained within a type 304 stainless steel housing with bag in, bag out attachment and prefilter. Advise factory of specific contaminant and volume so proper carbon can be supplied. Filter rated at 1000 CFM. One filter required for 48"and 60"hoods; 2 filters required for 72" hoods.			51198	51198	51198

**Questions / Ready to order**  
**Call 1-800-779-4362**

	48"	60"	72"
<b>Width "A"</b>	48"	60"	72"
<b>Width "C"</b>	38"	50"	61"
<b>Diameter "D"</b>	10"	10"	12"

**Fume Hood Face Velocity**   
 The recommended face velocity for efficiency & safety is 80-100 FPM. Lower face velocity may compromise user safety.  
 Sash in full open position should be for setup of apparatus & maintenance service only. Design opening is at 1/2 open at 100 FPM (feet per minute), face velocity at full open would be approximately 50 FPM.

Size hood	48"	60"	72"
1/2 open CFM	385	474	592
Full open CFM	773	938	1162



**Air Flow Monitor**  
 (Optional equipment) continuously monitors face velocity air flow, meets ANSI and OSHA requirements.  
**Cat. No. 51403** (see page 39)

**Sash Stop** located at 1/2 open position to reduce air flow volume 50%, provides best possible user protection and safety.  **Cat. No. 51651**

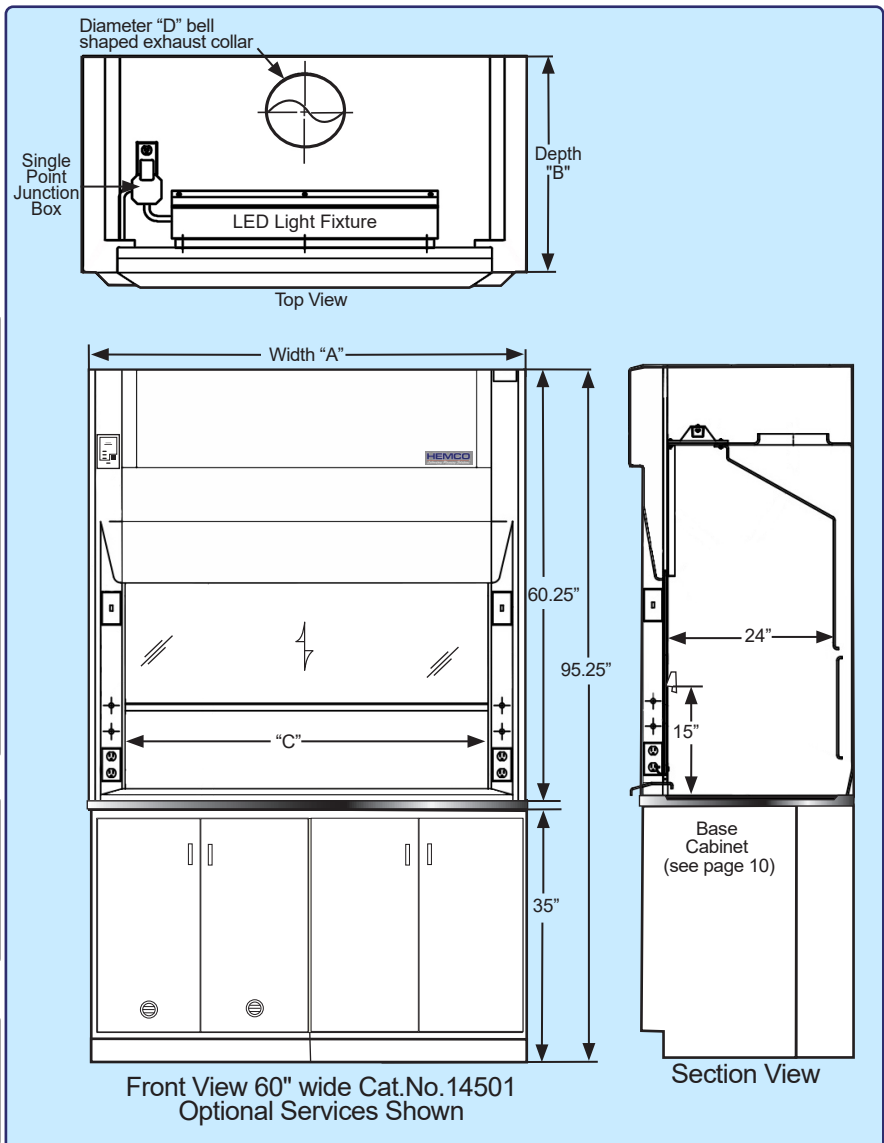



# UniFlow Fume Hood Chemical Applications

One-piece Integral Fume Chamber. Exterior composite FRP Super Structure for total chemical & corrosion resistance. Meets NFPA-45 fire resistance requirements, For use of plastics in laboratories. Any heat generating equipment should be elevated 2" to 3 inches above worksurface, and 4" to 6" inches away from side walls and rear baffle system, and at least 6" away from the sash opening.

## HiPel Fiberglass Composite Fume Hood



HEMCO FRP composite dual wall Superstructure unitized with integral FRP fume chamber. All fiberglass reinforced plastic side walls, rear wall, baffle system, air foil, exhaust collar, ceiling, with explosion proof light fixture. Available with Epoxy, Phenolic or Stainless steel worksurface. Make the AireStream SE, LE and CE the ideal fume hoods. See page 3

## Type 316 Stainless Steel Perchloric Acid Fume Hood



HEMCO HiPel FRP composite dual wall Superstructure unitized with integral stainless steel fume chamber. All 316 stainless steel side walls, rear wall, baffle system, exhaust collar, ceiling, with explosion proof light fixture. Integral recessed 316 stainless steel worksurface, air foil, and wash down system make the ideal Perchloric Acid fume hood. See page 25

## PVC Perchloric Acid Fume Hood



HEMCO HiPel FRP composite dual wall Superstructure unitized with integral PVC fume chamber. All PVC side walls, rear wall, baffle system, exhaust collar, ceiling, with explosion proof light fixture. Integral recessed PVC worksurface, air foil, and wash down system make the ideal Perchloric Acid fume hood. See page 25

## HDPE Acid Digestion Fume Hood



HEMCO FRP composite dual wall Superstructure unitized with integral HDPE fume chamber. HEMCO HDPE High Density Polyethylene side walls, rear wall, baffle system, air foil, exhaust collar, integral ceiling, with explosion proof light fixture. Integral High Density Polyethylene worksurface and air foil, make the ideal Acid Digestion fume hood. See page 27

## Polypro Trace Metals Fume Hood



HEMCO HiPel FRP composite dual wall Superstructure unitized with integral PolyPropylene fume chamber. All PolyPropylene side walls, rear wall, baffle system, air foil, exhaust collar, ceiling, with explosion proof light fixture. Integral recessed Polypropylene worksurface air foil, make the ideal Trace Metals fume hood. See page 29

## Type 304 Stainless Steel Radioisotope Fume Hood



HEMCO HiPel FRP composite dual wall Superstructure unitized with integral 304 Stainless steel fume chamber. All stainless steel side walls, rear wall, baffle system, air foil, exhaust collar, ceiling, with explosion proof light fixture. Integral recessed 304 Stainless steel worksurface and air foil, make the ideal Radioisotope fume hood. See page 31

# HEMCO Fume Hood Materials & Chemical Resistance Chart

UniFlow Fume Hoods are constructed of white composite Fiberglass Reinforced Polyester (FRP) material. FRP is an excellent general purpose material for fume hood construction.



- Superstructure features unitized dual wall construction with integral one-piece fume chamber for total chemical resistance, non-sparking construction, for hazardous locations.



- UniFlow HiPel FRP Composite construction is UL 1805 Classified for Laboratory Fume hoods and cabinets.

- HEMCO HiPel FRP Composite conform to NFPA 45 for products used in laboratories.

- To provide for the best airflow performance through the fume chamber, any heat generating equipment should be elevated 2" to 3" above work surface and 4" to 6" away from side walls and rear baffle system, and at least 6" away from the sash opening.

## Chemical resistance of HEMCO's most widely used FRP composite construction, and other liner material options.

**N** = No Effect    **S** = Slight Effect    **B** = Bad Effect    **NA** = Data Not Available

Chemical	HEMCO HiPel FRP Composite	Polyvinyl Chloride (PVC)	High Density Polyethylene (HDPE)	Polypropylene (PP)	304 Stainless Steel (SS)	316 Stainless Steel (SS)	Worksurfaces	
							Epoxy Resin	Phenolic Resin
Acetic Acid	N	N	NA	N	S	N	N	NA
Acetone	N	B	N	N	N	N	N	NA
Ammonium Hydroxide	N	N	NA	N	N	N	N (28%)	NA
Benzene	N	B	S	B	N	N	N	B
Carbon Tetrachloride	N	B	B	B	N	N	N	N
Chromic Acid	N	S	NA	B	N	N	S (40%)	B
Diethyl Ether	N	B	NA	B	N	N	N	NA
Ethyl Alcohol	N	N	N	N	N	N	N	NA
Gasoline	N	N	B	NA	N	N	N	N
Hydrogen Peroxide	N	N	N	N	NA	NA	N	B
Hydrochloric Acid	N	N	N	N	B	B	S	NA
Kerosene	N	N	NA	B	N	N	N	N
Methyl Alcohol	N	S	N	N	N	N	N	NA
Methyl Ethyl Ketone	N	B	B	NA	N	N	NA	N
Nitric Acid	N (20%)	N	N	B	B	B	N	NA
Sodium Chloride	N	N	N	NA	S (10%)	N (10%)	S (10%)	N
Sodium Hydroxide	N	N	N	N	N	N	S (10%)	B
Sodium Hypochlorite	N	N	B	N	N	N	N	NA
Sodium Sulfide	S	N	N	NA	N	N	NA	B
Sulfuric Acid	N (33%)	N (70%)	N (80%)	N	S (80%)	N (80%)	N (60%)	B (75%)
Sulfuric Acid (conc.)	S	S	S	N	B	S	B	B
Flame Spread	< 25	NA	NA	NA	0	0	NA	NA
Fuel Contributed	0	NA	NA	NA	0	0	NA	NA
Smoke Developed	500	NA	NA	NA	0	0	NA	NA

# **UNIMAX FLOOR MOUNTED (WALK-IN) FUME HOODS**

UniMax Floor Mounted (Walk-in) Hoods are designed to safely isolate equipment, materials, and procedures from the surrounding area and exhaust hazardous fumes.



**UniMax 16'w X 6'd X 12'h**  
**LED lighting, FG framed glass door with**  
**overhead sliding track, & center wall divider.**  
**Cat No. 161072**

## **UniMax FM Hoods Modular Construction**

UniMax Floor Mounted Hoods are supplied in standard models from 6' to 24' wide, with various depth and height options. The unique modular construction features 2" thick walls that have chemical and fire resistant composite resin U.L. 1805 compliant surface panels, and meets ASTM E-84. This also allows the hood to ship knockdown and be moved through standard lab entry doors for easy on site assembly.

## **Engineered To Meet Your Project Requirement**

Equipped with vapor proof fluorescent light, LED, or, explosion proof light fixtures that are available, in 115V 60Hz or 230V 50Hz electrical service. All factory installed. (see page 36)

## **UniMax Entry Access Door Options:**

**Add FG, FS, SC suffix to model number.**

**FG – Framed Glass Door with Overhead Sliding Track** Supplied with (4) doors on (2) tracks, doors slide horizontally in an overhead track.

**FS – Framed Glass Door with Floor Sliding Track** Supplied with (4) doors on (2) tracks, doors slide horizontally in a lower floor track. The floor track threshold is 0.75" high.

**SC – Strip Curtains** Clear vinyl strip curtains provide containment in addition to the ability to move drums, cylinders, or equipment easily through for processing or storage.



# UNIMAX FLOOR MOUNT (WALK-IN) HOOD DESCRIPTIONS

Select UniMax hood size width A, select height B, select depth

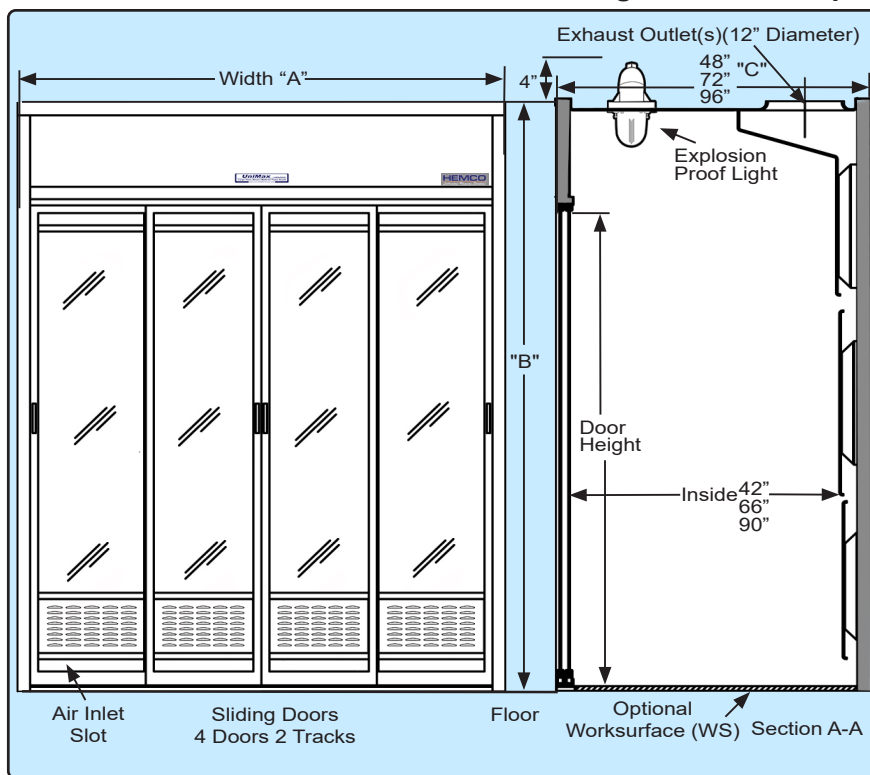

Dimensions		Depth "C"			Number of Exhaust Outlets
Width "A"	Height "B"	48" outside 42" inside	72" outside 66" inside	96" outside 90" inside	
6'	8'	60848	60872	60896	(1) 12" Dia
	10'	61048	61072	61096	
	12'	61248	61272	61296	
8'	8'	80848	80872	80896	(2) 12" Dia
	10'	81048	81072	81096	
	12'	81248	81272	81296	
10'	8'	100848	100872	100896	(2) 12" Dia
	10'	101048	101072	101096	
	12'	101248	101272	101296	
12'	8'	120848	120872	120896	(3) 12" Dia
	10'	121048	121072	121096	
	12'	121248	121272	121296	
16'	8'	160848	160872	160896	(4) 12" Dia
	10'	161048	161072	161096	
	12'	161248	161272	161296	
20'	8'	200848	200872	200896	(5) 12" Dia
	10'	201048	201072	201096	
	12'	201248	201272	201296	
24'	8'	240848	240872	240896	(6) 12" Dia
	10'	241048	241272	241296	
	12'	241248	240272	240296	

## Fume Hood Fire Suppression System for UniMax

Recommended for potentially flammable or volatile applications. System is designed to meet various fire classifications and sized to fit the specific interior cubic dimensions of UniMax.  
(see page 14 or consult factory for details)



## Distillation Apparatus Grids

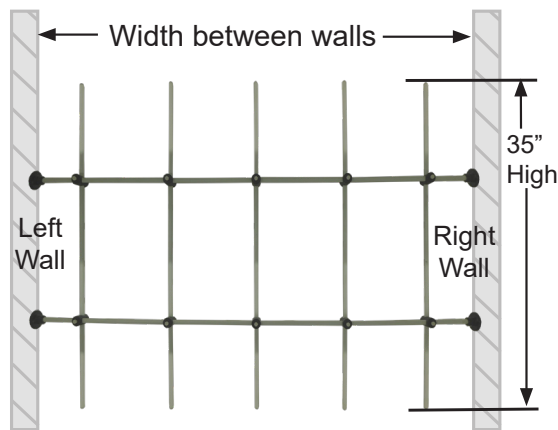

- Aluminum parts furnished with satin finish.
- Stainless steel parts type 316 stainless
- FRP rod parts are acid resistant
- (Consult factory for details)

## UniMax Explosion Proof Lighting Options

**Explosion Proof Light Fixture** UL listed.  
Class I Div II  
Groups A,B,C,D, Class II  
Div II Groups F & G.  
For use in hazardous locations.  
(bulb not included)  
115V or 230V. not wired.  
**Cat. No. 50034**



**Explosion-Proof Light Fixture** UL listed.  
Class I Div I Group C,D,  
Class II Div I Group E, F,G.  
For use in hazardous locations.  
Accepts bulb up to 300  
watts, (bulb not included)  
115 / 230V. not wired.  
**Cat. No. 50038**



## HazMax Spill Containment Basins

HazMax floor mounted hoods are differentiated by having a molded one-piece seamless composite resin spill containment basin. The basin is 8" high and includes a raised fiberglass deck grating.



- ✓ Lower basin is of molded one-piece seamless chemical resistant composite resin construction to safely contain accidental spillage.
- ✓ Raised deck grating is of chemical resistant fiberglass material that allows spillage to flow through to basin below, self draining can be accommodated. Containment basin can be engineered to contain a specified volume of liquid.
- ✓ Engineered to meet the anticipated weight loads.
- ✓ Convenient lift out grating allows access to basin for cleaning and decontamination.
- ✓ Lower basin can be engineered to accommodate fork lift requirements.

# Laboratory Ventilation Recommendations

Proper placement and use of fume hoods and blowers are important laboratory ventilation requirements. HEMCO offers the following suggestions to help in your laboratory layout. For technical support please contact HEMCO.

## Location of Hood

- Room air supply, air flow patterns and user convenience are the most important considerations in planning the location of hoods within the laboratory.
- Hoods placed directly in front of doors, open windows, or air conditioning registers will not perform efficiently. Drafts create turbulence at the face of the fume hood and disrupts air flow.
- Hoods should not be placed where users would be forced to work in the line of traffic. Traffic in front of the hood adversely affects fume hood air flow.
- When common exhaust or supply systems are used for several hoods, the hood units should be arranged so minimum amount of ductwork is required. See page 39 for more suggestions on planning your ducting system.
- Hoods used as general lab exhaust should generally be located on the opposite wall from the side-wall inlet registers or doors. The hoods should be located so that air from the registers or diffusers sweep through the laboratory area first then into the hoods.

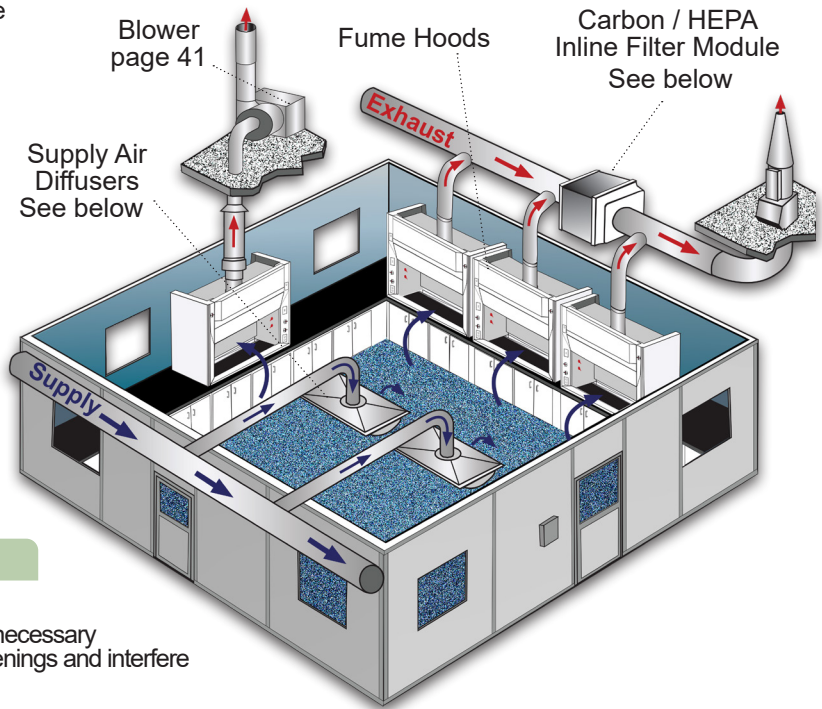

## Hood Operation

- Consult Lab Safety Officer for correct use of fume hood.
- Hoods should not be used as laboratory storage space. Unnecessary material or unused bottles and flasks can block exhaust openings and interfere with hood performance.
- OSHA requires a fume hood be equipped with an Air Flow Monitor to track air flow velocities and warn operator of potentially dangerous low air flows due to damper, blower failure, blockage of ductwork system, or extreme sash opening height.

## Fume Hood Radial Flow Supply Air Diffuser

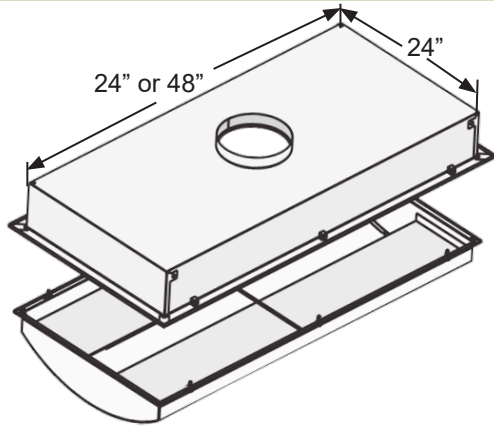

The Radial Flow Diffuser is designed to provide high volume / low velocity airflow into laboratory space specifically where fume hoods are located.

The uniform / low velocity airflow prevents turbulence at the hood face and efficiently distributes supply air to ensure correct air change that supports fume hood air volume requirements.

Available duct sizes: 8 or 10 inches for 24 x 24 inch models, and 10 or 12 inches for 48 x 24 inch models.

- 24" X 24" 200-500 CFM ..... Cat. No. 90011
- 24" X 48" 400-1,000 CFM..... Cat. No. 90012

## Clean Air In-Line Carbon and or HEPA Filtration Systems

HEPA Filter Paks effectively collect particulate contaminants from the exhaust air stream.



Filters can be grouped together end to end for HEPA and Carbon, or side by side for greater airflow volume. (Consult factory)

### Clean Air Carbon Filter Pak

CFM	Size	Duct Size	Cat. No.
250-650	26" x 15" x 3.5"	4", 8" diameter	50297
650-1200	26" x 26" x 35.5"	8", 10", 12" diameter	50298

### Carbon Filters

CFM	Size	Cat. No.	CFM	Size	Cat. No.
500	24" x 12" x 12"	52100	500	24" x 12" x 2"	52000
1000	24" x 24" x 12"	52101	1000	24" x 24" x 2"	52001

### Prefilter (6 per carton)

### Clean Air HEPA Filter Pak

CFM	Size	Duct Size	Cat. No.
250-650	26" x 15" x 35.5"	4", 8" diameter	50188
650-1200	26" x 26" x 35.5"	8", 10", 12" diameter	50189

### HEPA Filters

CFM	Size	Cat. No.	CFM	Size	Cat. No.
500	24" x 12" x 12"	50094	500	24" x 12" x 2"	52000
1000	24" x 24" x 12"	50095	1000	24" x 24" x 2"	52001

### Prefilter (6 per carton)



# Energy Savings Recommendations

A comparison of two fume hoods below is based on a designed 12" high operating sash height with sash management and a full open sash height without sash management. By maintaining a lower operating height, energy can be conserved, material costs saved, and user safety enhanced. Sash Management can SAVE 57% on fume hood operating cost.

## Energy Savings



1. UniFlow 72" CAV bypass fume hood **WITHOUT** sash management requires 1170 CFM to maintain 100 FPM (face velocity) with the sash fully open. At an average of \$7.00 per CFM, the annual cost to operate this fume hood would be \$8190.00

2. UniFlow 72" CAV bypass fume hood **WITH** sash management only requires 500 CFM to maintain 100 FPM (face velocity) with operating height at 14". At an average of \$7.00 per CFM, the annual cost to operate this fume hood would be \$3500.00

**Total Energy SAVINGS = \$4690.00 per year**

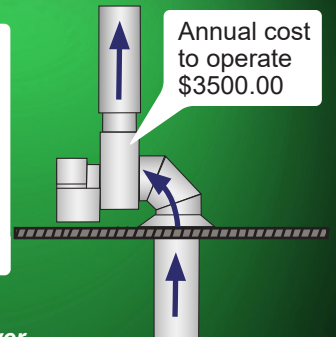

## Equipment Savings

Based on 20' of ducting, (1) 90° elbow, stack outlet, and exhaust blower

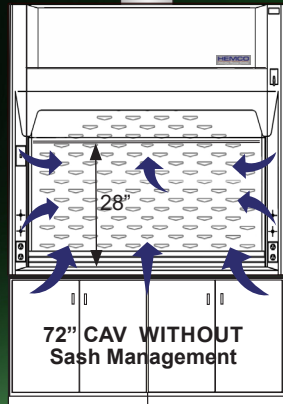

UniFlow 72" CAV bypass fume hood **WITHOUT** sash management would require 12" diameter ducting to handle the volume and duct velocity at \$200.00 per foot.

UniFlow 72" CAV bypass fume hood **WITHOUT** sash management an exhaust blower designed to maintain 100 FPM (face velocity) would require 1170 CFM @ 0.75" w.g. (static pressure) with a 10" diameter inlet and 1/2 hp motor at \$3720.00

UniFlow 72" CAV bypass fume hood **WITH** sash management would only require 8" diameter ducting to handle the volume and duct velocity at \$143.00 per foot.

UniFlow 72" CAV bypass fume hood **WITH** sash management an exhaust blower designed to maintain 100 FPM (face velocity) with sash at 14" operating height, would only require 500 CFM @ 0.75" w.g. (static pressure) with a 9" diameter inlet and 1/4 hp motor at \$3264.00

**Total Equipment SAVINGS ducting & blower = \$1617.00**

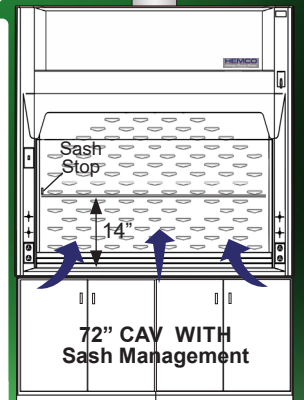

## Importance of Duct Velocity

**Duct Velocity** is important to the safe ventilation of laboratory fumes & particulate, 1200 to 1500 FPM (duct velocity) is recommended. A 72" fume hood with 1170 CFM (for full sash opening) will have a 12" diameter belled outlet duct connection & will maintain 1400 FPM duct velocity. A 72" fume hood with 500 CFM (for 12" sash opening) will have an 8" diameter belled outlet duct connection & will maintain 1400 FPM duct velocity for over a 50% reduction in volume.

## Importance of Room Air Changes per Hour

**10-12 Air Changes per Hour** is typical to a laboratory and in some cases the fume hood not only exhausts hazardous fumes but serves as the general ventilation of the lab. The lab should always be under negative pressure; thus 10% of the exhaust should come in from the corridor under or around the door. For example, a 12' x 25' x 9' high room, at 2700 cu ft, would require approximately 450 CFM. With the hood at 500 CFM and 10% of that coming from the corridor, the minimum supply in the room would be 450 CFM. However if a greater amount is brought in, there would need to be general exhaust from the room to prevent the room from being pressurized.

**Make-Up Air,** Considering that a fume hood exhausts a large amount of air from the lab space, it is necessary to ensure that there is sufficient air supply to the lab, yet still maintaining a negative air pressure to the surrounding area.

Because of the additional resistance in the duct system, the static pressure of inline filtration would need to be calculated when sizing the exhaust fan.

**Filtration,** Depending on the contaminant, an inline HEPA or carbon filter may be necessary to prevent pollution to the outside environment. (see page 43 for filtration options)

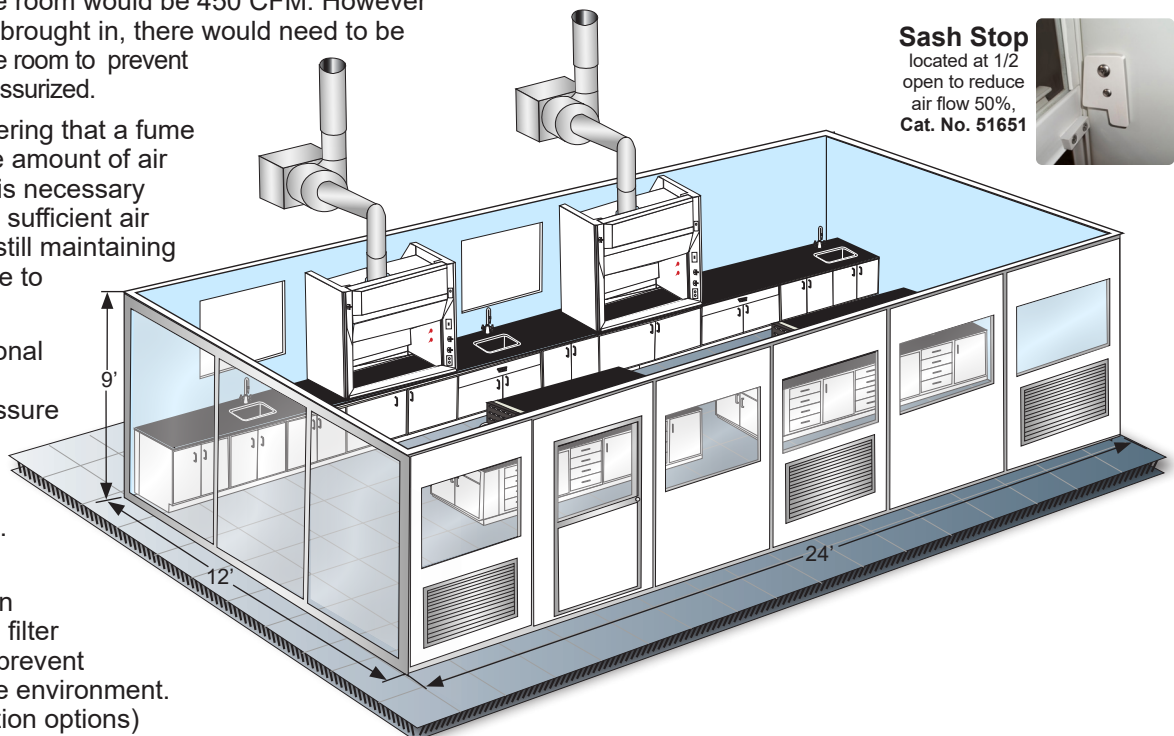



# Fume Hood Ventilation and Duct Design

Ductwork connected to fume hoods may be arranged in a variety of patterns depending on requirements. Generally, the best exhaust system involves the shortest duct length and the fewest elbows. Duct size, length, and number of elbows affect static pressure loss and blower efficiency. Ideally, each fume hood should have its own ducting and blower to maximize hood flexibility and reduce danger of back draft from other hoods.

Common or manifold ductwork designs can be used, provided duct and blower have been sized properly. In these designs, individual hood dampers are recommended to balance the system. Hood users must be aware of how different hood exhaust fumes will react when mixed in the ductwork. Rigid PVC ductwork is recognized as an excellent fume hood exhaust duct material. The smooth interior surface reduces static pressure loss and chemical waste build up, and PVC is extremely resistant to a wide variety of reagents. For some applications flexible PVC lined duct provides adequate service and can significantly reduce installation costs. When planning exhaust ducting, duct size, length, number of bends, and exhaust material must be considered. Consult HEMCO for Lab Ventilation Solutions.

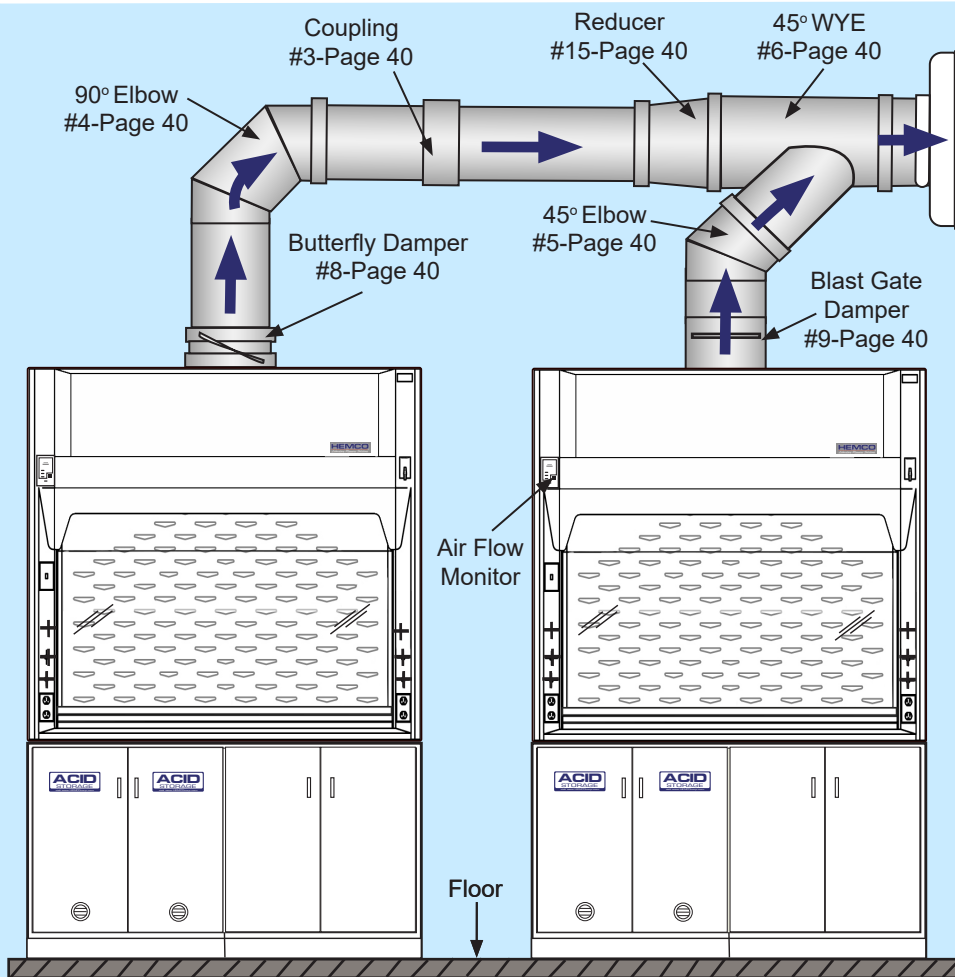
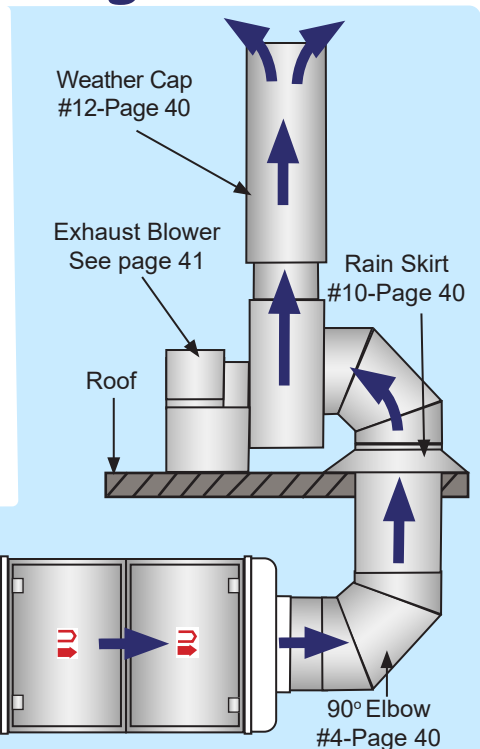

**Air Flow Monitors**  
 Note: OSHA recommends air flow alarms to be installed on all fume hoods.

**Air Flow Monitor Analog**  
 Continuously monitors face velocity air flow of fume hood. Select and calibrate at desired FPM velocity set point. If the hood face velocity falls below set point, an audible alarm sounds and a visual red indicator light appears. Air flow alarm is factory installed or can be field installed, 115/60Hz AC.  
 Cat. No. 51403

**Air Flow Monitor with Digital Display**  
 Continuously monitors face velocity air flow of fume hood. A digital display of face velocity in m/sec or FPM that indicates safety reading with an audible alarm. Push button calibration and 3 programmable input/output relays. Factory installed or can be field installed.  
 Cat. No. 51410

**Air Flow Monitor Intrinsically Safe**  
 For applications where the fume chamber is classified but the surrounding lab space is not. Continuously monitors face velocity air flow of fume hood. If the hood face velocity falls below set point, an audible alarm sounds and a visual red indicator light appears. Factory installed or can be field installed.  
 Cat. No. 51404



**Minihelic Gauge**  
 Gauge monitors the pressure across the HEPA filter. Gauge mounts on the fume hood or on the filter housing. Measure range is from 0 to 2.0" wg. accurate within 5%. Gauge is 3" dia.  
 Cat. No. 51300



**Magnehelic Gauge**  
 Gauge measures static pressure across the HEPA filter. Can mount on the fume hood or the filter housing. Range of measurement is from 0 to 2"wg. dia. accurate within 2%. Gauge is 5"  
 Cat. No. 51301













**Mini Photohelic Gauge**  
 Mini-Photohelic differential pressure gauge with two SPDT switching set points, is designed to measure and control positive, negative, or differential pressures consisting of noncombustible and non-corrosive gasses. Gauge is 3" dia.  
 Cat. No. 51302

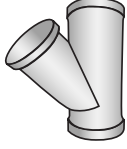
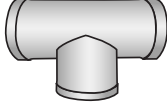

**DigiHelic Gauge**  
 Gauge allows selection of pressure, velocity, or volumetric flow operation. Menu keys to access 5 menus which provide access to security level, selection of pressure, velocity of flow operation, and selection of engineering units. Gauge is 3" dia.  
 Cat. No. 51303

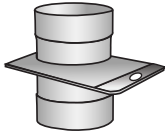
# Fume Hood Ductwork & Venting Accessories

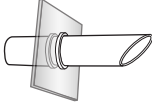
Ducting and accessories are chemical resistant and easy to install.

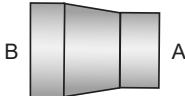
Flexible and Rigid PVC Ducting		4"	6"	8"	10"	12"	14"
	<b>1. Flexible Ducting</b> neoprene impregnated fiberglass reinforced with steel helix wire. Standard 12' lengths. Each piece includes 2 stainless steel clamps.	Cat. No. 80051	Cat. No. 80052	Cat. No. 80053	Cat. No. 80054	Cat. No. 80055	Cat. No. 80056
	<b>2. PVC Rigid Ducting</b> chemical resistant for permanent installations. Standard 10' lengths with straight ends.	Cat. No. 82004	Cat. No. 82006	Cat. No. 82009	Cat. No. 82011	Cat. No. 82013	Cat. No. 82015
	<b>3. PVC Coupling</b> required to connect straight sections.	Cat. No. 82147	Cat. No. 82149	Cat. No. 82153	Cat. No. 82157	Cat. No. 82159	Cat. No. 82160
	<b>4. PVC 90° Elbow</b> used in order to offset obstacles. Has belled ends for duct connections.	Cat. No. 82060	Cat. No. 82061	Cat. No. 82063	Cat. No. 82066	Cat. No. 82068	Cat. No. 82069
	<b>5. PVC 45° Elbow</b> used in order to offset obstacles. Less static pressure loss than a 90° elbow. Has belled ends for duct connections.	Cat. No. 82082	Cat. No. 82083	Cat. No. 82085	Cat. No. 82087	Cat. No. 82089	Cat. No. 82090
	<b>6. PVC 45° WYE</b> lateral for joining common ductwork in multiple hood designs. Branch diameter may be sized to 2" to 4" smaller than main diameter. Has belled ends for duct connections.	Cat. No. 82216	Cat. No. 82218	Cat. No. 82226	Cat. No. 82229	Cat. No. 82233	Cat. No. 82234
	<b>7. PVC Tee</b> used in manifold exhaust systems. Has belled ends for duct connections.	Cat. No. 82034	Cat. No. 82036	Cat. No. 82038	Cat. No. 82040	Cat. No. 82044	Cat. No. 82046
	<b>8. PVC Butterfly Damper</b> modifies CFM for single or multiple hood arrangement. Has belled ends for duct connections.	Cat. No. 82450	Cat. No. 82452	Cat. No. 82454	Cat. No. 82456	Cat. No. 82458	Cat. No. 82460
	<b>9. PVC Blast Gate Damper</b> a gate that slides in and out to control CFM. Has belled ends for duct connections.	Cat. No. 82369	Cat. No. 82371	Cat. No. 82373	Cat. No. 82375	Cat. No. 82377	Cat. No. 82379
	<b>10. PVC Rain Skirt</b> slips over straight pipe on roof to slope water away from cutout.	Cat. No. 82328	Cat. No. 82330	Cat. No. 82332	Cat. No. 82334	Cat. No. 82336	Cat. No. 82337
	<b>11. PVC Vent Outlet</b> for horizontal venting through wall or window. Angled end prevents rain from entering. Male connector included.	Cat. No. 80074	Cat. No. 80076	Cat. No. 80077	Cat. No. 80078	Cat. No. 80079	Cat. No. 80080
	<b>12. Zero Pressure Weather Cap</b> discharges fumes vertically away from roof. Self-draining. Minimal static pressure loss. This is the recommended weather cap.	Cat. No. 82350	Cat. No. 82352	Cat. No. 82354	Cat. No. 82356	Cat. No. 82358	Cat. No. 82359
	<b>13. Round to Round Transition</b> to smaller duct diameter. Diameter "A" - "B"	Cat. No. 82613 4"- 6"	Cat. No. 82615 6"- 8"	Cat. No. 82617 8"- 10"	Cat. No. 82619 10"- 12"	Cat. No. 82620 12"- 14"	Cat. No. 82621 14"- 16"

# Fume Hood Exhaust Blowers Ordering Info

A complete line of belt and direct drive exhaust blowers that are chemical resistant & available in standard and explosion-proof models. HEMCO blowers are designed to operate effectively and efficiently to remove noxious & hazardous fumes. Standard 115V 60Hz & international electrical configuration of 220V 50Hz AC available.

## Blower Recommendations

1. Blowers should be mounted on the roof in-order that the ducting leading to the blower inlet is under negative static pressure. If exhaust blowers are mounted inside the building, all ducting connected to the blower outlet will be under positive static pressure, if a leak were to develop in the section of the duct inside the building, toxic and or hazardous fumes could be forced out of the ductwork and into that area of the building.
2. To achieve the lowest practical noise level in the exhaust system, we suggest that the following measurements be used when there is no conflict with other specifications of the system:
  - a. Use vibration isolators or mounting blower exhaust assembly.
  - b. Install a blower fan that will deliver the correct CFM and static pressure with the lowest practical impeller wheel RPM. If possible, use a duct size large enough to keep duct velocity under 1800 FPM velocity.
  - c. Use a flexible connection at the fan inlet to isolate mechanical transmission of noise from the ducting between the hood and the exhaust blower.
3. Exhaust blower system should be designed with the fewest possible elbows or other fittings. Use radius type elbows & avoid using square elbows. Use gradual tapered transitions where necessary, & avoid abrupt changes in configuration or cross sectional area.
4. When ordering an exhaust blower, specify the orientation of discharge desired. Vertical up blast discharge is the most common and will be supplied unless otherwise specified.
5. All fans are shipped with clockwise rotation when viewed from the motor end of the assembly.
6. For normal usage, the standard for both the blower housing and impeller wheel is epoxy coated.
7. Blowers used for hood exhaust at altitudes above 1,000 feet, may require a correction factor to provide the correct CFM and static pressure.

Contact factory for details relating to your specific application.

## Epoxy Coated Steel Belt Drive Blowers

Standard (STD) belt drive steel blower and impeller wheel are epoxy coated for superior chemical resistance. Explosion-proof blowers (EXP) have epoxy coated, non-sparking aluminum impeller wheel. V-belt drive and adjustable pulleys permit field balancing. Seven discharge positions to suit installation. Weather housing is furnished. Motor has thermal overload protection. Specify: 115V single phase, 230V single phase, 230/460V three phase or 208V(consult factory). 1 year manufacturer's warranty

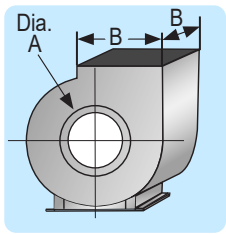

Catalog Number and Static Pressure														
CFM	A Inlet Dia	B Outlet Size	1/2" Static Pressure			3/4" Static Pressure			1" Static Pressure			1 1/2" Static Pressure		
			HP	STD	EXP	HP	STD	EXP	HP	STD	EXP	HP	STD	EXP
296	8 7/8"	10 1/8" x 4 1/8"	1/4	51701	51801	1/4	51702	51802	1/4	51703	51803	1/4	51704	51804
800	8 7/8"	10 1/8" x 6 3/8"	1/2	51713	51813	1/2	51714	51814	1/2	51715	51815	3/4	51716	51816
914	9 7/8"	11 1/2" x 8 1/4"	1/2	51717	51817	1/2	51718	51818	—	—	—	—	—	—
1240	9 7/8"	11 1/2" x 8 1/4"	1/2	51725	51825	1/2	51726	51826	3/4	51727	51827	3/4	51728	51828
1771	11 7/8"	13 3/8" x 8 1/4"	1/2	51734	51834	3/4	51735	51835	3/4	51736	51836	1	51737	51837

## Epoxy Coated Steel Direct Drive Blowers

Direct drive steel blower and impeller wheel are epoxy coated for superior chemical resistance. Explosion proof blowers have epoxy coated non-sparking aluminum impeller wheels. Motor is 115V, single phase and has thermal overload protection. 1 year manufacturer's warranty

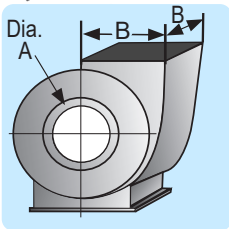

Catalog Number and Static Pressure								
A Inlet Diameter	B Outlet Size	HP	STD	EXP	1/4" SP	1/2" SP	3/4" SP	1" SP
					Free Air CFM	Free Air CFM	Free Air CFM	Free Air CFM
6"	7" X 4-3/8"	1/6	51177	51178	565	515	440	300
8"	8-3/4" X 5-7/16"	1/3	51179	51180	935	875	800	712
9"	10-1/8" X 4-1/8"	1/2	51181	51182	1050	980	920	850
9"	10-1/8" X 5-1/8"	3/4	51183	51184	1260	1220	1180	1100

Standard motors are 115V / 60Hz / 1 phase. Explosion proof motors are 115/230V, 60Hz, 1 phase. Other voltage, hertz, and phase motors are available.



# Fume Hood Exhaust Blowers Ordering Info

HEMCO offers a complete line of chemical resistant non-metallic exhaust blowers in belt drive or direct drive options in standard or explosion proof models. Ideal for applications where corrosion resistance is critical. These blowers are available in polypropylene or fiberglass construction.

## Blower Recommendations

1. It is recommended that exhaust blowers be located at the end of the ducting which is typically roof mounted. This ensures a negative pressure through out the ventilation system. However for applications where the duct is going directly out through a wall above a fume hood, one option is to have a fiberglass direct drive blower installed in the top of the fume hood. By having the blower internally mounted, the installation is simplified and convenient for duct connection and servicing. However there would be an airflow sound element associated to having the blower hood mounted.
2. By keeping the exhaust duct as short and as straight as possible, the total resistance will be reduced and by keeping the diameter of the duct correctly sized to the flow volume, noise and static pressure can be reduced.
3. Blower wheels for polypropylene and fiberglass blowers are polypropylene.
4. Vibration isolators are recommended when mounting the blower assemblies
5. HEMCO recommends that a sash stop be installed on the fume hood to limit the sash height for operation. By having stop at a half open position, the total CFM can be reduced by 50%; thus by reducing the volume, energy loss, duct diameter, motor and blower size, and sound is reduced.

UniFlow SE & LE Fume Hoods			
Hood Width	Hood Depth	Full Open CFM	1/2 Open CFM
36"	30"	438	241
48"	30"	772	385
60"	30"	938	474
72"	30"	1162	592
96"	30"	1613	800
UniFlow CE Fume Hoods			
Hood Width	Hood Depth	Full Open CFM	1/2 Open CFM
30"	24"	378	189
36"	24"	460	230
48"	24"	654	327
72"	24"	960	480

## Blower Description

- CFM at 100 FPM face velocity
- Housing is constructed of either molded composite or polypropylene for chemical resistance.
- Flange inlet collars enable easy connection to ductwork.
- Wheel is dynamically balanced to minimize noise and increase efficiency.
- Belt drive models have Ball bearing pillow blocks which are pre-lubricated and resistant to both moisture and dirt.
- Shaft is constructed of polished steel with a coating to prevent rust and corrosion.
- Motors meet NEMA standards for single speed motors.
- These blowers are ideally suited for both supply and exhaust applications in laboratories, educational, pharmaceutical, industrial, and other applications.

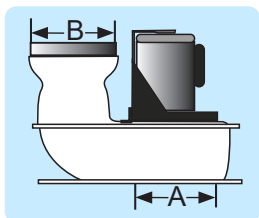

## Vertical Intake Vertical Discharge Blowers

Vertical Intake Vertical Discharge Blowers, mounted in the interstitial ceiling space of the fume hood. Blower housing is constructed of FRP for chemical resistance. Direct drive blower and impeller wheel are epoxy coated for superior chemical resistance. Explosion proof blowers have epoxy coated non-sparking aluminum impeller wheels. Motor is 115V, single phase and has thermal overload protection. Available on UniFlow SE, and CE fume hoods. 1 year manufacturer's warranty

Catalog Number and Static Pressure								
Free Air CFM	A Inlet Diameter	B Outlet Size	HP	STD	EXP	1/4" SP	1/2" SP	3/4" SP
						CFM	CFM	CFM
160	6"	4"	1/6	51060	51061	115	--	--
280	6"	6"	1/4	51062	51063	200	125	--
590	8"	8"	1/2	51064	51065	500	450	350
685	10"	10"	1/2	51068	51069	550	425	300

## Polypropylene Belt Drive Blowers

High efficiency impellers produce low power consumption, reduced operating costs and quiet operation. 20 forward curved blades, in fire retardant polypropylene. Non-static and oil resistant V-belt, cast iron pulleys, adjustable pulleys available, adjustment for tensioning and belt replacement. 230V explosion proof, non sparking, chemical resistant for hostile or hazardous environments. 115V single phase or three phase. Non-static and oil resistant V-belt, cast iron pulleys, adjustable pulleys available, adjustment for tensioning and belt replacement. 1 year manufacturer's warranty

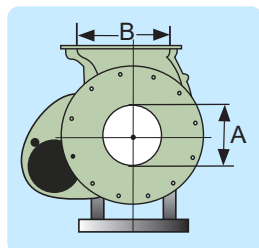

Catalog Number and Static Pressure											
Free Air CFM	A Inlet Diameter	B Outlet Diameter	0.5" Static Pressure HP			0.75" Static Pressure HP			1.0" Static Pressure HP		
			HP	STD	EXP	HP	STD	EXP	HP	STD	EXP
400	6"	6"	1/4	51450	51850	1/4	51460	51860	1/4	51470	51870
800	8"	8"	1/4	51451	51851	1/3	51461	51861	1/3	51471	51871
1000	8"	8"	1/2	51452	51852	1/2	51462	51862	1/2	51472	51872
1200	10"	10"	1/2	51453	51853	1/2	51463	51863	1/2	51473	51873
1600	10"	10"	1	51754	51854	1	51464	51864	1	51474	51874

# Clean Air In-Line HEPA Filtration Systems

HEMCO HEPA Filter Paks effectively collect particulate contaminants from the exhaust air stream. HEPA filters are 99.999% effective at removing particulate .3 micron and larger. The filter pak housing features a hinged access door with gaskets and spring latches for convenient filter change. Inlet and outlet plenums with duct connection collars are installed. The HEPA Filter Pak can also be paired with a carbon filter pak to remove chemical fumes and odors. Designed to clean up fumes from Fume hood.

## Clean Air In-Line HEPA Filtration Systems to suit fume hood requirements

Note: HEMCO recommends a minihelic or magnehelic gauge to monitor the air flow differential across the filter. The static pressure indicated would alert when to change filter. The gauges can be hood or filter mounted.

We recommend ordering a back-up replacement filter. Designed to clean up fume hood exhaust fumes.



Clean Air HEPA Filter Pak					
CFM	Size		Duct Size	Cat. No.	
250-650	26" x 15" x 3.5"		4", 6", 8" diameter	50188	
650-1200	26" x 26" x 3.5"		8", 10", 12" diameter	50189	
HEPA Filters			Prefilter (6 per carton)		
CFM	Size	Cat. No.	CFM	Size	Cat. No.
500	24" x 12" x 12"	50094	500	24" x 12" x 2"	52000
1000	24" x 24" x 12"	50095	1000	24" x 24" x 2"	52001

## HEPA Bag In-Bag Out Systems to suit fume hood requirements

**Filter Housing is fabricated of type 304 stainless steel and requires (1) HEPA filter absorber, (1) 24" X 24" X 2" 30% pleated prefilter and (1) bag.**

Bag-In bag-out filters are designed to meet air filtration requirements to handle hazardous fumes and vapors. The housing incorporates a ribbed bagging ring around the side access door over which a specially designed plastic bag is attached. Filters are then installed and changed through the bag to reduce the risk of exposure to personnel.



Clean Air HEPA Filter Bag-In Bag-Out System (see below)				
Description	CFM	Size	Cat. No.	
Clean-Aire HEPA Filter Bag-In Bag-out System	1000	26" X 26" X 35.5"	51189	
HEPA Filters	1000	24" X 24" X 12"	50195	
HEPA Prefilter ( 6 per carton)	1000	24" X 24" X 2"	52001	
Replacement Bags (2 per carton)			51989	

## Clean Air In-Line Bag-In / Bag-Out Filtration Systems (BIBO) to suit fume hood requirements

**The filtration system is rated at 1800 CFM and includes a stainless steel housing with lift off and gasketed access doors for filter change-out and inlet and outlet plenums with duct connection collars sized to meet specification. Bubble tight dampers allow system to close off for filter change.**

- Initial filters supplied (excludes pre filters)
- Initial change out bags supplied.
- Inlet/outlet duct connection flanges shall be a minimum of 1.5" wide.
- Approximate shipping weight: 1100 LBS. (without filters)
- Approximate operating weight: 1350 LBS.
- A minimum of four (4) feet of clearance in front of access door is recommended for filter change-out.

**Cat. No. 58998-1** (1) HEPA and Carbon Inline

**Cat. No. 58998-2** (2) HEPA and Carbon InLine



# Clean Air In-Line Carbon Filtration Systems

HEMCO Carbon Filter Paks are used in laboratory exhaust and supply systems to remove chemical odors and vapors from the airstream. Filters are loaded with virgin coconut activated carbon to efficiently absorb organic solvents and acid fumes. The filter pak housing features a hinged access door with gaskets and spring latches for convenient filter changes. Inlet and outlet plenums with duct connection collars are installed. The carbon filter pak can also be paired with a HEPA Filter Pak to collect particulate contaminants. Designed to clean up fume hood exhaust fumes.

## Clean Air In-Line Carbon Filtration Systems to suit fume hood requirements

Note: A standard "01" activated carbon filter for organics is included. HEMCO recommends the sampling kit to check if there has been a breakthrough in the carbon filter, and ordering a back-up replacement filter.



Clean Air Carbon Filter Pak					
CFM	Size		Duct Size	Cat. No.	
250-650	26" x 15" x 35.5"		4", 6", 8" diameter	50297	
650-1200	26" x 26" x 35.5"		8", 10", 12" diameter	50298	
Carbon Filters			Prefilter (6 per carton)		
CFM	Size	Cat. No.	CFM	Size	Cat. No.
500	24" x 12" x 12"	52100	500	24" x 12" x 2"	52000
1000	24" x 24" x 12"	52101	1000	24" x 24" x 2"	52001

## Carbon Bag In-Bag Out Systems to suit fume hood requirements

Filter housing is fabricated of type 304 stainless steel and requires (1) carbon filter absorber, (1) 24" X 24" X 2" 30% pleated prefilter and (1) bag.

Bag-In bag-out filters are designed to meet air filtration requirements to handle hazardous fumes and vapors. The housing incorporates a ribbed bagging ring around the side access door over which a specially designed plastic bag is attached. Old filter is removed then new filters are then installed and changed through the bag to reduce the risk of exposure to personnel. Note: The carbon filter is not included with the housing. We also, recommend a sampling kit to check if there has been a break through in the carbon filter, and ordering a back-up replacement filter.



Clean Air Carbon Filter Bag-In Bag-Out System				
Description	CFM	Size	Cat. No.	
Clean-Aire Carbon Filter Bag-In Bag-out System	1000	26" X 26" X 35.5"	51198	
Carbon Filters	1000	24" X 24" X 12"	52111	
Carbon Prefilter ( 6 per carton)	1000	24" X 24" X 2"	50001	
Replacement Bags (2 per carton)			51999	

## Radioisotope Bag In-Bag Out Filtration System to suit fume hood requirements

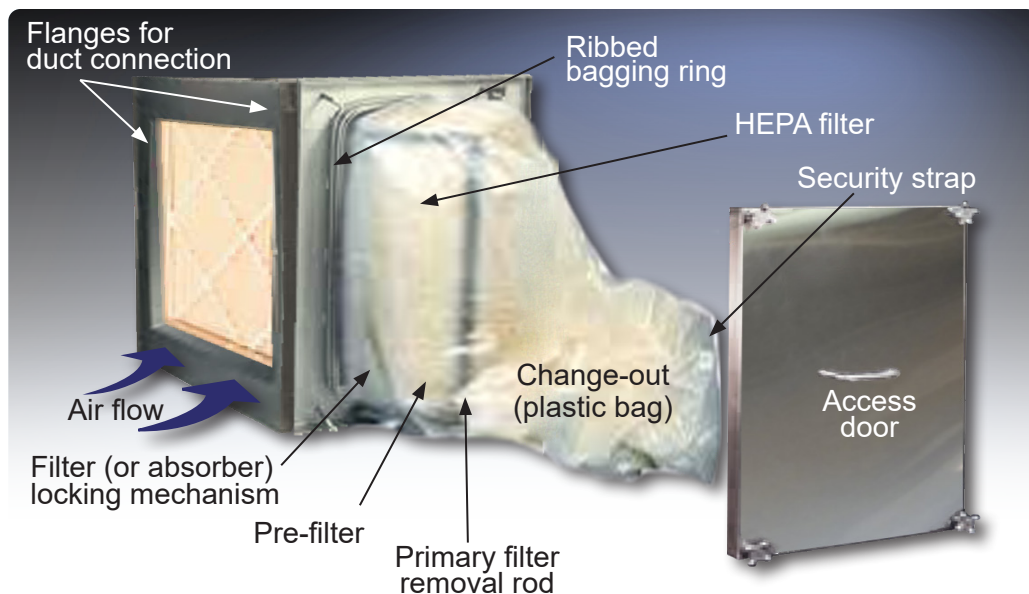

### Gas Monitor

Gas Monitor detects and warns of high concentrations of dangerous gases such as chlorinated solvents, ammonia, ethylene oxide, etc. Unit has visual and audio alarm and is factory calibrated to specific gas. 115V and power cord. Specify gas and alarm level.

Cat.No. 51400



# Polypropylene Fume Hood Scrubbers



Fume Hood Scrubber is designed for laboratories that require removal of acid vapors from exhausted air, under the most demanding corrosive environmental conditions. These Scrubbers are compact vertical venturi units for indoor installations only.

- Low operating cost
- Sizes from 8" to 20", larger sizes available
- Highly effective for water soluble acids
- No moving parts to wear out or replace
- Installs directly into exiting duct systems
- Average installation time 2 hours with minimal tools
- Uses no packing material to clog or replace
- Allows the isolation of individual hoods or tanks that require pollution reduction
- Low water consumption at a minimum 8 gallons per hour
- Can be ducted if necessary to meet venting requirements
- Designed to clean up fume hood exhaust fumes.

*The design of the inline fume scrubber is based on the need for a simple, compact, efficient, and water conservative apparatus for the removal of particulates and water soluble vapors from individual laboratory fume hoods.*

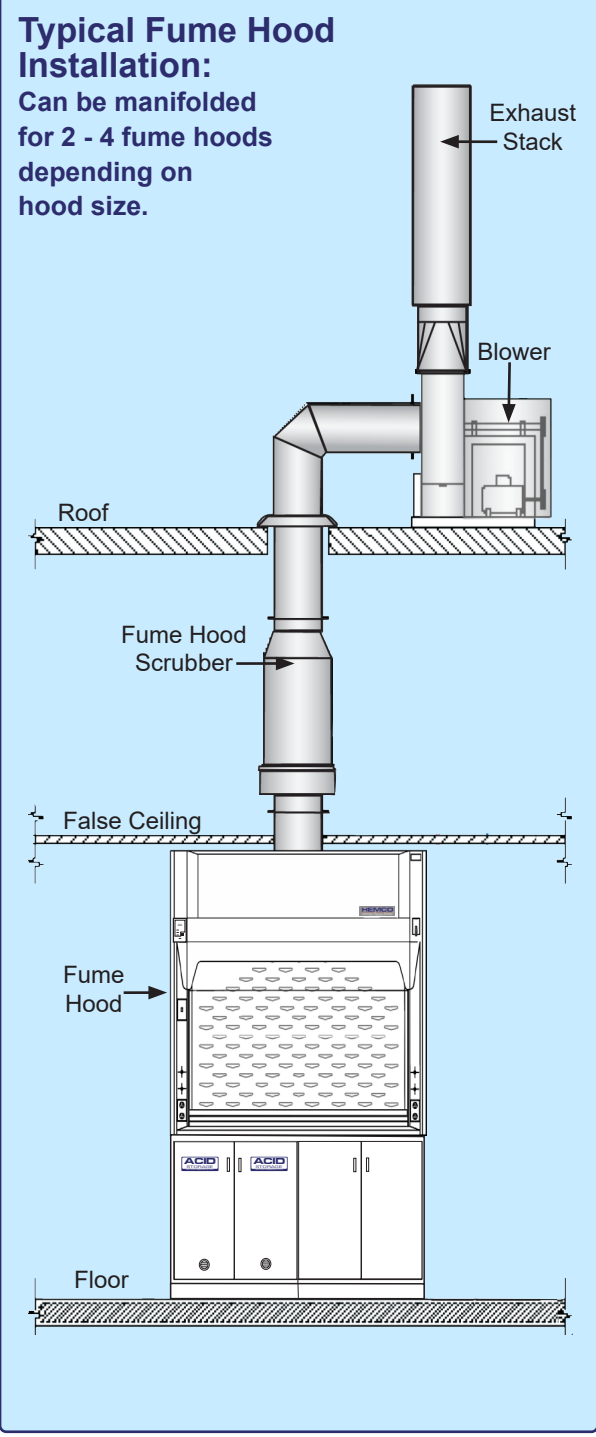
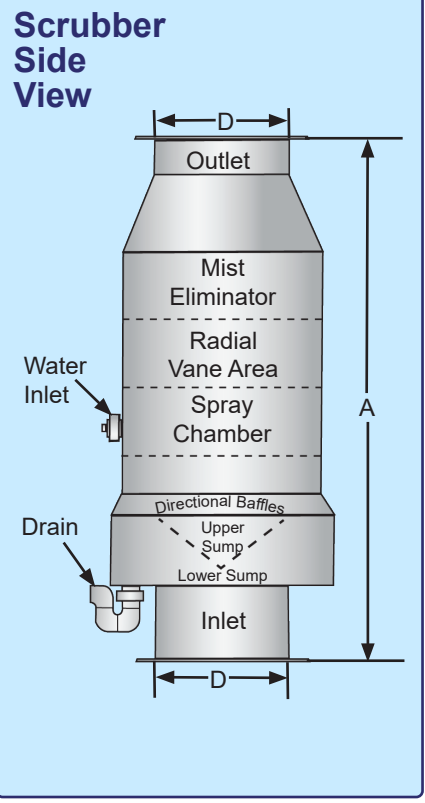

Recirculation System						
Optimal Air Volume	240-250 CFM	580-720 CFM	890-1000 CFM	1590-1735 CFM	1950-2400 CFM	2400-3052 CFM
Overall Height "A"	38.75"	44.77"	50.75"	61.75"	73.537"	78.5"
Inlet Diameter "D"	8"	10"	12"	15"	18"	20"
Cat. No.	Cat. No.	Cat. No.	Cat. No.	Cat. No.	Cat. No.	Cat. No.
PolyPro Construction	85008	85010	85012	85015	85016	85018

# Clean Air Fume Hood Scrubbers

Scrubber systems offer high efficiency & minimal maintenance on meeting pollution control requirements. Can be manifolded for 5 - 10 fume hoods exhaust.



## Remote Recirculation Pump

Can be supplied for installations where the scrubber is located outdoors and the possibility of freezing is present.

CFM	Cat. No
500	80210
1000	80211
2000	80212
4000	80213
6000	80214
8000	80215



**Fume Scrubbers** provide excellent air pollution control for water soluble fumes and odors by moving contaminated air through a filter pack media exposing over forty square feet of surface per cubic foot. Containment is collected on filter media surface and rinsed off with water, excess water is then mechanically removed and cleaned air is released. When conditions require, chemical additives can increase absorptive capacity of the scrubber. Unit includes integral recirculation tank and pump which significantly reduces water consumption and related waste disposal costs. Fan is not included, must be sized to meet exhaust requirements. Request a Plan-A Scrubber specification sheet for planning your scrubber. Designed to clean up fume hood exhaust fumes.

## PH Control Package

Allows precise control over effluent quality and provides neutralization of contaminants. The PH control system consists of a weather tight, corrosion-proof enclosure containing an analyzer, pre-wired chemical feed pump, weather-protected terminal block, clear PVC face plate and external chemical-feed connection. Enclosure can be mounted on any vertical surface. A heavy-duty industrial probe with a 10" lead wire is supplied, along with (2) 10" lengths of vinyl tubing to connect the feed pump.



Cat. No. 80112

Atmospheric Contaminant	Catalog Number and Fume Removal Efficiencies (based on a 3 foot Bed)	
	5 Foot Bed Series	With pH Control Package
Acetic Acid Mist	NR	90-95%
Alcohols	*	*
Alkaline Mists, General	99.9%	99.9%
Aqua Regina Gas	95-98%	96-98%
Ammonia Gas	NR	98-99%
Chlorine	NR	95-98%
Chromic Acid	99%	99%
Cyanide Solutions	99.9%	99.9%
Fluoborate Mist	99%	99%
Formaldehyde	NR	98-99%
Haldid Mist	98%	98%
Hydrofluoric Acid	96-99%	98-99%
Hydrogen Cyanide	NR	95-98%
Nickle Sulfate	99%	99%
Nitrogen Dioxide	*	*
Perchloric Acid	85-90%	95-98%
Phosphoric Acid	85-90%	95-98%
Sodium Sulfide	99%	99%
Sulfamate Mist	99%	99%
Sulfuric Acid	99.9%	99.9%
Zinc Chloride	95%	95%

The above efficiencies are intended as a guide representing average values. Specific combinations and concentrations of fumes may result in a significant variation from the above. \* Requires extended packing depth and chemical addition to scrubber solution.

## Horizontal Air Flow Scrubber

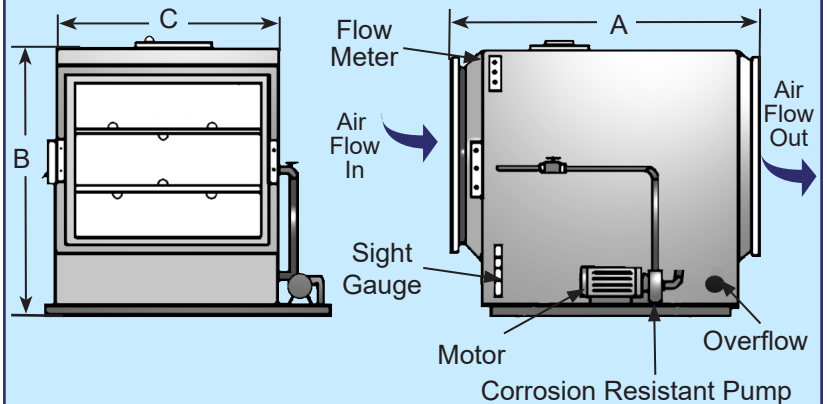

Size	Scrubber			Cat.No.	Blower	
	A	B	C		Size	Cat.No.
500 CFM	49"	30"	18"	80000	500 CFM	80010
1000 CFM	50"	34"	22"	80001	1000 CFM	80011
2000 CFM	50"	40"	28"	80002	2000 CFM	80012
3700 CFM	52"	49"	37"	80003	3700 CFM	80013
6000 CFM	53"	58"	45"	80004	6000 CFM	80014
8000 CFM	54"	65"	52"	80005	8000 CFM	80015

# Laboratory Furniture Groupings

UniLine design incorporates our most popular casework groupings to meet your laboratory needs. Welded steel with chemical resistant, epoxy powder coat finish, and 1" thick phenolic resin countertops, 4" high backsplashes, and flush ends standard. Standard height 36", ADA height 34", and sitting height 28" options are available. Standard color: Lab White. (optional colors are available as required) Groupings can be supplied with optional Fume hoods.

## Atlantis Grouping

Atlantis Grouping provides basic lab storage & a versatile work area. Cabinet grouping includes 3 standing height cabinets with rear filler panels on both ends, phenolic resin worksurface 36" high, with 4" high back splash. Includes 16" X 12" X 8" sink and H/C gooseneck faucet.

Atlantis Cabinet Grouping					
Width	1	2	3	24" Depth Cat. No.	30" Depth Cat. No.
108"	36"	36"	36"	70011	70021
120"	36"	48"	36"	70012	70022
144"	48"	48"	48"	70013	70023

## Enterprise Grouping

Enterprise Grouping provides a convenient balance of storage and work space. Cabinet grouping includes 3 standing height cabinets with rear filler panels, 2 wall cabinets, phenolic resin worksurface 36" high, with 4" high back splash. Includes 16" X 12" X 8" sink, 30" X 30" pegboard and H/C gooseneck faucet.

Enterprise Cabinet Grouping					
Width	1	2	3	24" Depth Cat. No.	30" Depth Cat. No.
108"	36"	36"	36"	70211	70221
120"	36"	48"	36"	70212	70222
144"	48"	48"	48"	70213	70223

## Endeavour Island Grouping

Endeavour Grouping is a flexible design that can serve as an island or peninsula layout. Cabinet grouping includes either 3 or 7 standing height cabinets with front and end filler panels, phenolic resin worksurface, and center island reagent shelf with pedestals and phenolic resin shelf. Includes 16" X 12" X 8" sink, 30" X 30" pegboard and H/C gooseneck faucet.

Endeavor Cabinet Grouping					
Width	1	2	3	4	Cat. No.
101"	36"	36"	—	60"	71311
137"	36"	36"	36"	60"	71312
173"	48"	48"	48"	60"	71313

## Viking/Magellan Grouping

Viking Grouping is ideal for medical examination rooms and small lab requirements. Cabinet grouping includes 1 or 2 standing height cabinets, 1 wall cabinet 36" or 48" wide, 24" high 12" deep, phenolic resin worksurface. Includes 16" X 12" X 8" sink and H/C gooseneck faucet.

Viking Cabinet Grouping				
Width	1	2	24" Depth Cat. No.	30" Depth Cat. No.
72"	36"	36"	70413	70423
96"	48"	48"	70414	70424

Magellan Sink Cabinet Grouping			
Width	1	24" Depth Cat. No.	30" Depth Cat. No.
36"	36"	70611	70621
48"	48"	70612	70622

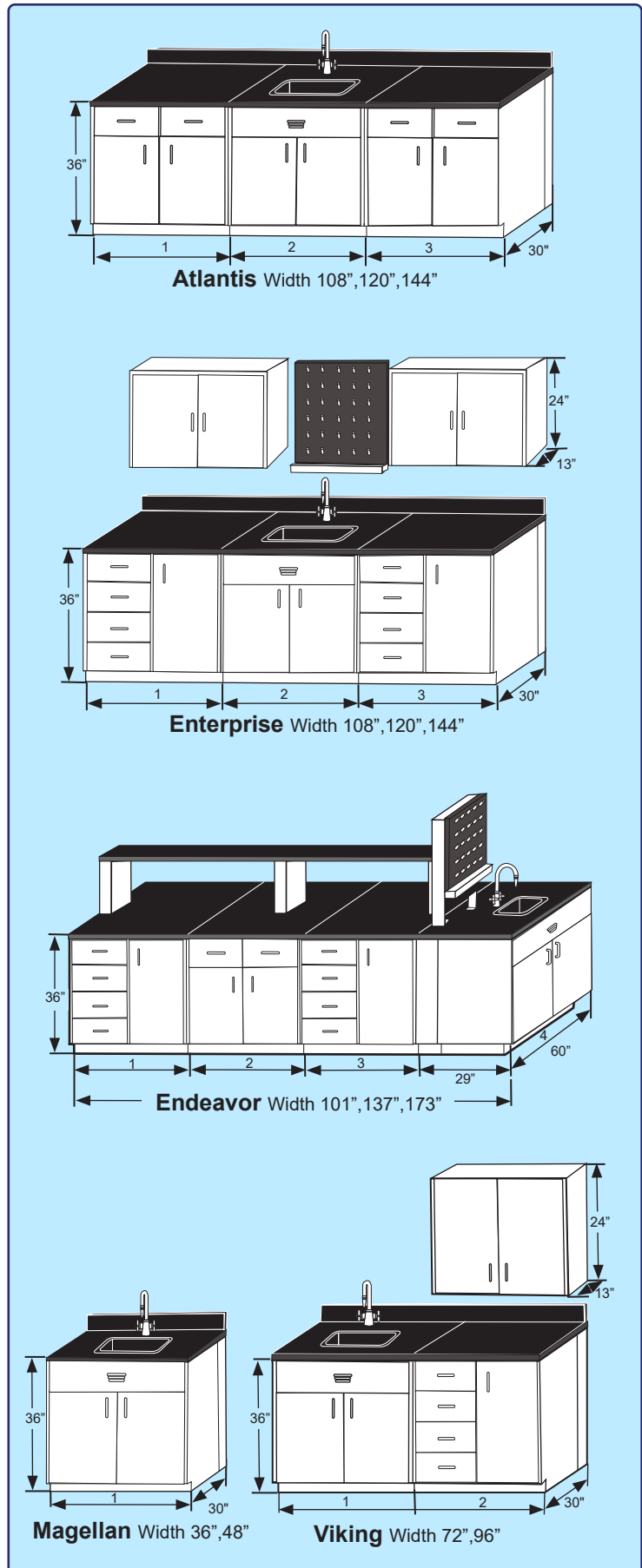



# HEMCO Plan-A-Lab Worksheet showing Groupings

The HEMCO Plan-A-Lab enables you to conveniently lay out your lab furniture and your pre-engineered modular clean lab. For more information request the Modular Clean Room Brochure. Shown below is a 20' X 24' (2) wall system. Existing walls in black, new walls in yellow slash mark.

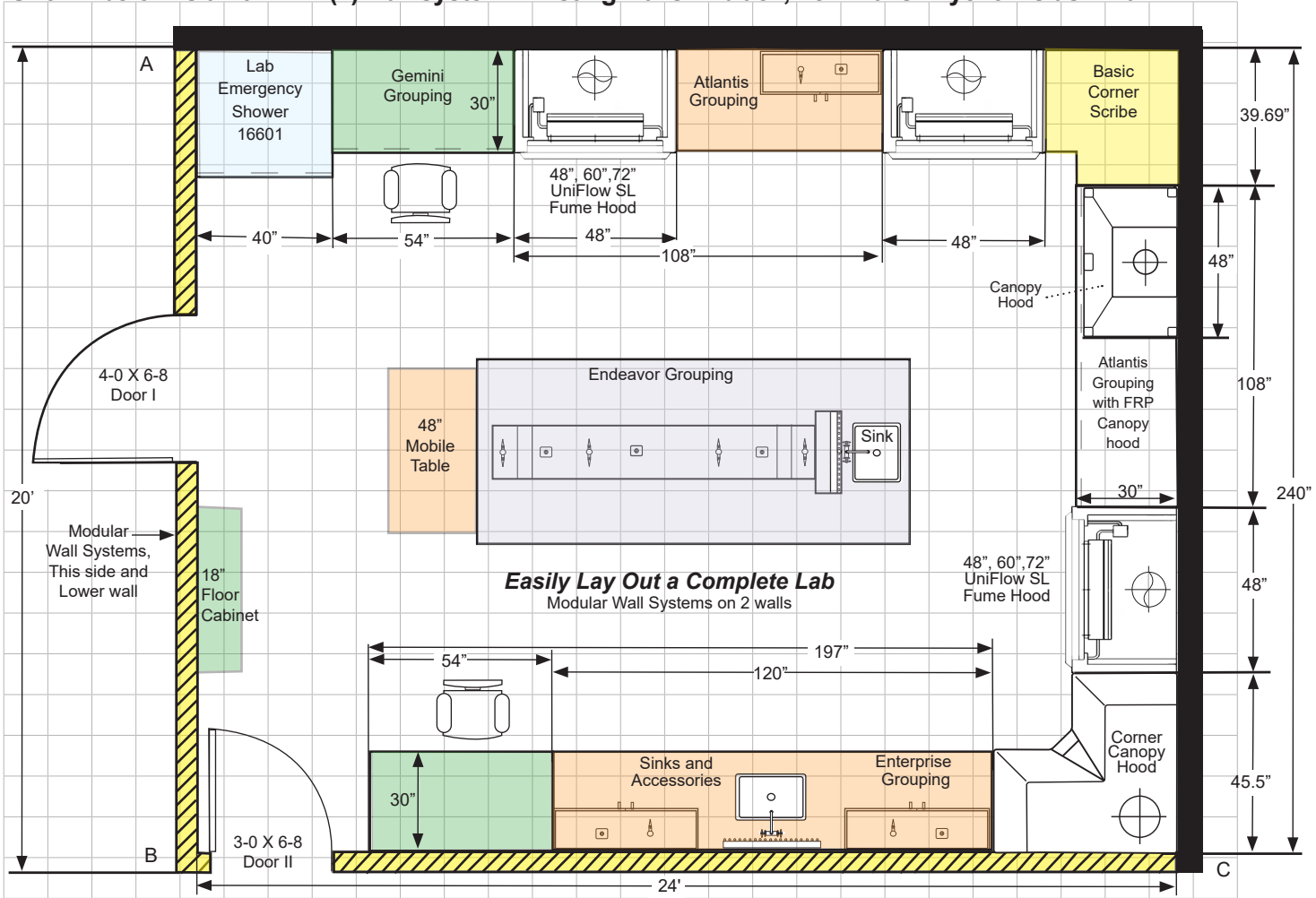

For Lab Planning worksheet visit: [www.hemcocorp.com/images/Literature/PlanALab.pdf](http://www.hemcocorp.com/images/Literature/PlanALab.pdf) shown above 20' X 24' (2) wall system

## UniLine Laboratory Casework Construction (SEFA 8 Compliant)



UniLine Casework is constructed of welded 18 gauge steel. Powder coat finish is environment friendly, attractive and long lasting, color: Lab White. Modular design allows for simple field conversion from inlet to overlay, door and drawer re-configurations and hardware component changes. Casework is tested independently to be SEFA 8 load bearing capacity compliant.



**Drawer Bodies** constructed of 20 gauge steel. 18 gauge drawer suspension with full extension ball bearing drawer slide. File drawer suspension available in both 100 and 150 lb capacity. Exterior is urethane powder coated steel, for chemical and abrasion resistance.

**Doors** double wall construction with 20 gauge reinforcing channel (1) per door. Rubber door bumpers (4) per door. Five knuckle hinges (2) per door. Nylon roller catch (1) per door. Urethane powder coated steel. Manual, self closing.

**Cabinet Interior** Full length & width adjustable 20 gauge steel shelf for maximum storage. Zinc plated adjustable steel shelf clips. Powder coated finish for chemical resistance. 18 gauge full height removable access panel. Color: Lab White

**Recessed Toe Space** promotes laboratory cleanliness. Cabinet base lower corner reinforcing gusset with 0 to 2-1/2" zinc leveling bolts on (all four corners). Cabinet height adjustable from 35" to 37". 12 gauge steel corner gusset (4) each cabinet.

# Canopy Hoods

Canopy hoods are designed to collect and exhaust corrosive vapors, heat, steam, and odors when mounted over areas with water baths, hot plates, or portable equipment. Standard color: Lab White

## Wall Canopy Hoods (FRP or stainless steel, Includes wall mounting kit) (custom sizes available)

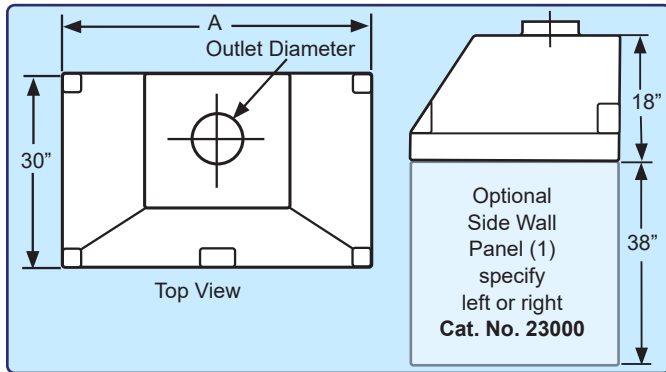

**Side Wall Panel**  
(fiberglass or stainless steel)  
kit includes one wall panel  
and hardware.  
**Cat. No. 23000**

**Rear Wall Panel**  
(consult chart for Cat.No.)

**Vapor Proof Light  
& Switch Cat. No. 50035**

**Blower Switch 115V/15A  
Cat. No. 50028**

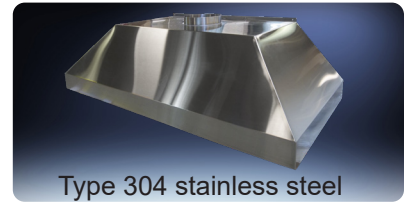

Type 304 stainless steel



For blowers (see page 41) For base cabinets (see page 10)

Width A	36"	48"	72"	96"	Side Wall Panels
<b>Fiberglass Cat. No.</b>	<b>13030</b>	<b>13040</b>	<b>13060</b>	<b>13080</b>	<b>23000</b>
<b>Fiberglass Rear Wall Panel</b>	<b>23016</b>	<b>23026</b>	<b>23036</b>	<b>23046</b>	--
<b>Stainless Steel Cat No.</b>	<b>13130</b>	<b>13140</b>	<b>13160</b>	<b>13180</b>	<b>23011</b>
<b>Stainless Steel Rear Wall Panel</b>	<b>23116</b>	<b>23126</b>	<b>23136</b>	<b>23146</b>	--
<b>Diameter D</b>	6"	8"	10"	(2) 10"	--

## Island Canopy Hoods (FRP or stainless steel) (custom sizes available)

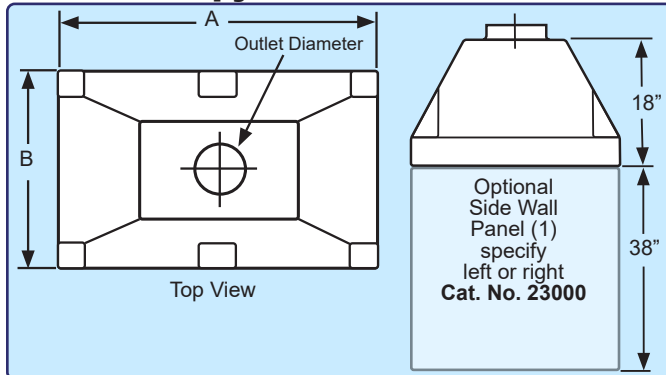

**Suspended Island Canopy  
Hood Mounting Kit** Includes  
all components to secure to ceiling  
including 6' long threaded rods.  
**Cat. No. 23001**

**Side Wall Panel**  
(fiberglass or stainless steel)  
kit includes one wall panel  
and hardware. **Cat. No. 23000**

**Rear Wall Panel**  
(consult chart for Cat.No.)

**Vapor Proof Light  
& Switch Cat. No. 50035**

**Blower Switch 115V/15A  
Cat. No. 50028**



Type 304 stainless steel



For blowers (see page 41) For base cabinets (see page 10)

Width A	36"	48"	72"	96"	Side Wall Panels
<b>Fiberglass Cat. No.</b>	<b>23030</b>	<b>23040</b>	<b>23060</b>	<b>23080</b>	<b>23000</b>
<b>Fiberglass Rear Wall Panel</b>	<b>23016</b>	<b>23026</b>	<b>23036</b>	<b>23046</b>	---
<b>Stainless Steel Cat No.</b>	<b>23130</b>	<b>23140</b>	<b>23160</b>	<b>23180</b>	<b>23011</b>
<b>Stainless Steel Rear Wall Panel</b>	<b>23116</b>	<b>23126</b>	<b>23136</b>	<b>23146</b>	---
<b>Diameter D</b>	6"	8"	10"	(2) 10"	---

## Corner Canopy Hoods (FRP, Includes wall mounting kit)

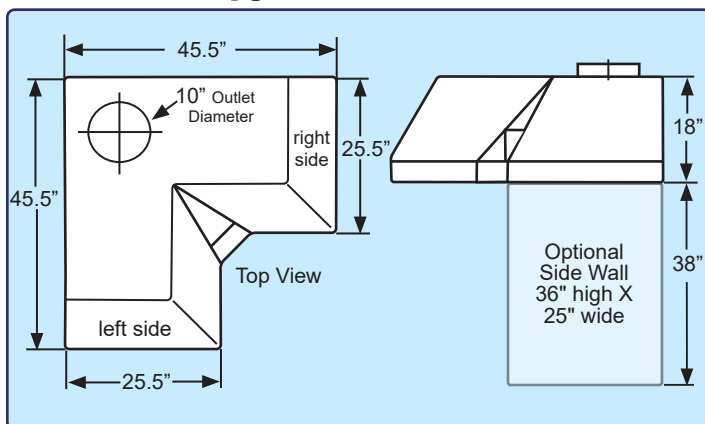

**Side Wall Panels** (fiberglass) 36" h X 25" w, kit includes one  
wall panel and hardware  
**Cat. No. 23006**

**Rear Wall Panels** (2) required  
Qty (1) 36" high X 45" wide  
**Cat. No. 23056**

**Vapor Proof Light &  
Switch Cat. No. 50035**

**Blower Switch 115V/15A  
Cat. No. 50028**

**Corner Composite Resin  
Worksurface** Gray, Comes  
dished to contain spillage.  
**Cat. No. 13503**

**Corner Table** Features  
White welded steel  
construction. **Cat. No. 13502**



**Corner Canopy** (includes mounting kit, to install canopy  
to two adjacent walls) **Cat. No. 13000**

# Laboratory Emergency /Shower Decontamination Booths

Full body emergency shower & eye / face wash, both with immediate response activation handle.

Durable one-piece seamless fiberglass construction with glass smooth white surfaces and covered corners for ease of clean-up.

Emergency showers available with translucent frosted strip curtains, which provides for easy access into booth, while containing contaminated water splash.

Stainless steel Grab bars located on right & left sides to support victim and rescue personnel during decontamination, included.

Plumbing is provided, for installation by local certified plumber. Plumbed to single point 1.25" IPT. connection. Tempered warm water supply connection 20 GPM water supply is required.

Raised fiberglass deck with self draining containment basin, and 2" diameter drain outlet located on either the bottom or rear of unit.

**Industrial Applications**  
**Emergency Drench Shower Booth**  
 unit is equipped with pull rod activated overhead drench shower and rear wall mounted eye/face wash.  
**Cat No. 16601**

**Laboratory Applications**  
**Emergency Drench Shower Booth**  
 same specs as above except with finished exterior side panels.  
**Cat No. 16604**



Cat. No. 16601  
 For Industrial Applications  
 shown above

*Note: OSHA & ANSI require that emergency shower is to be located within 10 seconds walking time from the hazardous site location.*



## Overhead Drench Shower

Shower unit features 10" diameter plastic head and 1" IPS brass "stay open" valve with rigid pull rod and handle. **Cat. No. 16088**



**Alarm Horn & Light**  
 Audible warning sound when system is activated by flow switch. Top mounted visual warning light when system is activated.  
**Cat. No. 16680**



## Eye/Face Wash

Wall mounting unit features two large plastic heads, push plate operated "stay open" ball valve. 1/2" IPS inlet, and 1.25" IPS drain. **Cat. No. 16006**

## Eye and Face Wash Options



**Hand Held Body Wash**  
 Squeeze valve nozzle on 8' coiled hose and bracket. Can be used to rinse all body parts while victim is sitting or lying down. Wall or hood mounted, 3/8 NPT, barrier free.  
**Cat No. 16005**



**Swing-Out Eye Wash**  
 Deck mounted next to sink. Activates when pivoted. 1/2" NPT. Barrier free.  
**Cat. No. 16009**



**Hand Held Eye/Face & Body Wash**  
 Mounted on the front side-wall of the fume hood. Includes 8' hose and surface escutcheon. 3/8" NPT. barrier free.  
**Cat. No. 93966**



# EnviroMax Vented Exhaust Enclosures



Project: Stanford University  
**Custom Enclosure features  
seismic levelers on the tables.**  
**Can be manufactured to your specifications.**

## **EnviroMax Vented Exhaust Enclosures protects personnel & containment processes**

### **A Vented Exhaust Enclosure offered in Unitized & Modular Designs for exhausting fumes from Robotic & Automated processes**

Designed to protect personnel from potentially hazardous fumes, vapors and odors. The enclosure can connect to in-house exhaust system or a dedicated exhaust blower, to provide the internal negative pressure needed to safely remove hazardous fumes from the work area. Air supply into the enclosure is supplied from the surrounding lab environment.

#### **EnviroMax Options**

- Access on any or all sides
- Multi-Plug strips
- Exhaust blowers
- Vertical slide or hinged doors
- Base cabinets
- Exhaust HEPA or carbon filters
- Other materials of construction
- Anodized aluminum & stainless steel framing
- Plumbing and electrical service fixtures
- Airflow Monitors
- Support benches & work surfaces
- Accessories

**For more information request the EnviroMax Enclosures for Robotic and Automated Lab Processes Brochure.**

**Contact us for custom enclosures built to your exact specifications or visit: [www.HEMCOcorp.com](http://www.HEMCOcorp.com)**

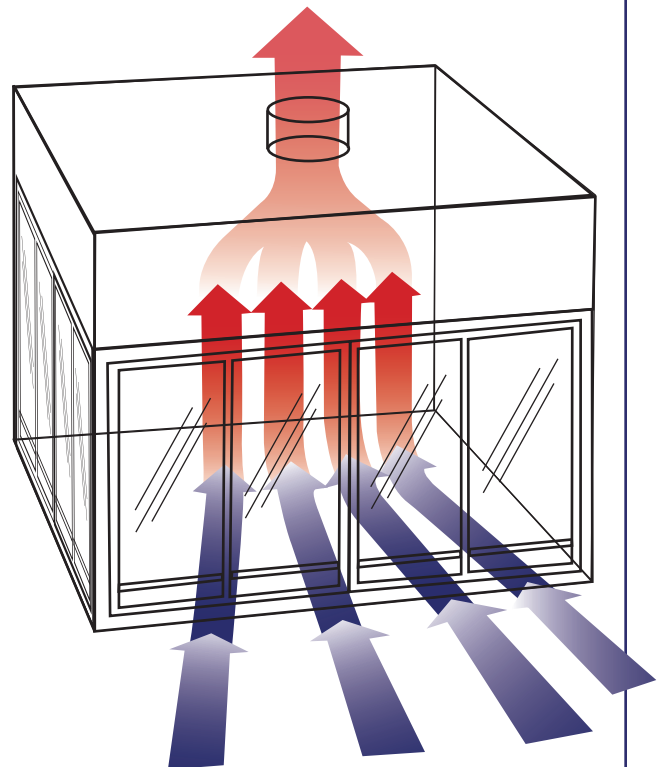

# EnviroMax Vented Exhaust Enclosures

Unitized Construction Sizes			
Width	Depth	Height	Cat. No.
48"	30"	48"	61041
60"	30"	48"	61051
72"	30"	48"	61061
96"	30"	48"	61081
48"	36"	48"	61042
60"	36"	48"	61052
72"	36"	48"	61062
96"	36"	48"	61082

## Unitized EnviroMax Vented Exhaust Enclosure sizes 4', 5', 6', and 8' wide by 30" & 36" deep by 48" high

Unitized design with depth of 30" and 36" to allow passage through door ways for easy on-site setup. Viewing from all four sides of the enclosed system. Access to interior of enclosure, available from any or all sides. Vent duct sized to airflow requirements. Pre-wired electrical connection to single point junction box. Under the bench storage and shelving designed to suit your requirements. Note: Custom sizes are welcomed.



Project: National Forensics & Coroners Complex, Canada  
**EnviroMax enclosure, unitized 120" wide X 36" deep X 48" high, with custom acid storage cabinets**

## Unitized EnviroMax Vented Exhaust Enclosure

Superstructure is welded steel framework with chemical resistant white powder coated finish. Side and rear walls are of clear acrylic or tempered glass. Ceiling is constructed of molded composite resin with the outlet duct connection collar sized for desired air volume. Slotted ceiling baffle allows air to flow evenly through the interior area into the exhaust plenum. The front of the enclosure features horizontal sliding shatter-proof clear viewing panels, (4) panels on (2) tracks allowing access at any position. Fluorescent light is factory installed and sealed behind a clear lens. Light switch is mounted on the front post. Provides an economical and flexible work space that exceeds stringent contamination requirements. All electrical components are U.L. listed.

Modular Construction Sizes			
Width	Depth	Height	Cat. No.
72"	48"	48"	62061
96"	48"	48"	62081
120"	48"	48"	62101
144"	48"	48"	62121
72"	60"	48"	62062
96"	60"	48"	62082
120"	60"	48"	62102
144"	60"	48"	62122

## Modular EnviroMax Vented Exhaust Enclosure sizes 6', 8', 10' & 12' wide by 48" & 60" deep by 48" high

Modular design with depth of 48" or 60" requires on-site assembly prior to setup and vent ducting. Pre-wired electrical connection to single point junction box. Work surface and support benches and cabinets sized to specifications. Provides an environment free of contamination for sensitive processes. Note: Custom sizes are welcomed.



Project: National Forensics & Coroners Complex, Canada  
**EnviroMax Modular enclosure size: 60" wide X 60" deep X 120" high with work surface & 60" wide X 60" deep X 24" high support table**

## Modular EnviroMax Vented Exhaust Enclosure

Superstructure is welded steel framework with chemical resistant white powder coated finish. Side and rear walls are of clear acrylic or tempered glass. Ceiling is constructed of molded composite resin with the outlet duct connection collar sized for desired air volume. Slotted ceiling baffle allows air to be drawn out evenly across the width of the interior into the exhaust plenum. The front of the enclosure features horizontal sliding tempered glass panels, (4) panels on (2) tracks allowing access at any position. Fluorescent light is factory installed and sealed behind a clear lens. Light switch is mounted on the front header panel. All electrical components are U.L. listed.

## EnviroMax Sash Options

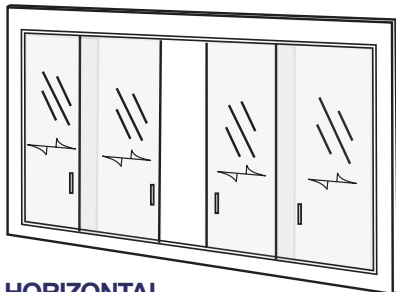

**HORIZONTAL SASHES** The standard sash for EnviroMax. The maximum sash opening for the horizontal sash is 1/2 that of the vertical sashes. The smaller opening, means less air exhausted resulting in energy savings.

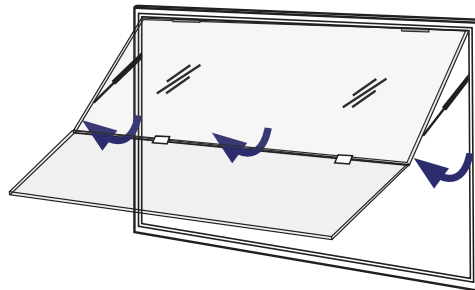

**OPTIONAL HINGED SASHES** Optional sash for EnviroMax. The sash may be hinged vertical rising or horizontal open for maximum access thru the fume chamber.

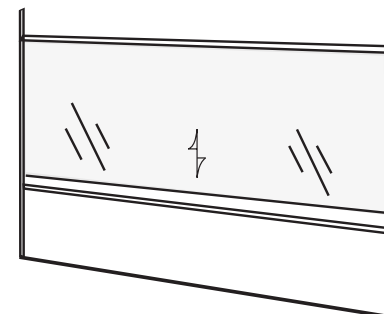

**OPTIONAL COUNTER BALANCED VERTICAL SASHES** The optional sash for EnviroMax. The sash may be lifted to the completely open position for maximum access tho the fume chamber. Sash stops available.



**Most Extensive Line of Laboratory Fume Hoods in the Industry  
Reduce Energy costs up to 50% with HEMCO Sash Management 1-2-3,  
which provides maximum energy efficiency and user protection.**



# UniFlow

**Laboratory Fume Hoods are available in**

1. Constant Air Volume CAV Air Bypass
2. Variable Air Volume VAV Restricted Bypass
3. Explosion Proof models for Hazardous Locations
4. CE models for International Electronic Configurations



Standard Bench Mount and Floor Mount hoods with over 40 standard sizes and custom sizes to your specs. UniFlow Superstructure exclusive unitized dual wall construction for total chemical resistance, strength, and durability. Performance tested to ASHRAE 110 - 1995. U.L. 1805 Classified for Fume Hoods & Cabinets, and SEFA1 Recommended Practices for Fume Hoods.

Request a free brochure At [www.HEMCOcorp.com](http://www.HEMCOcorp.com) and browse the entire selection of HEMCO Laboratory Equipment



Lab Planning Solutions  
Complete Laboratory  
Planning Guide



UniMax Large  
Floor Mount Walk-In  
Fume Hoods Brochure



EnviroMax Enclosures for  
Robotic and Automated  
Lab Processes



Modular Clean Labs  
& Quality Control Labs  
Brochure



Laboratory  
Ventilation  
Brochure



Find our products with [ARCAT.com](http://ARCAT.com)

**HEMCO Corporation**  
711 S. Powell Road  
Independence, MO 64056  
UFHC-06.24

**HEMCO**  
Laboratory Planning Solutions



**Specify UniFlow Fume Hoods  
on Your Next Lab Project**

Phone (816) 796-2900  
Fax (816) 796-3333  
[www.HEMCOcorp.com](http://www.HEMCOcorp.com)